



Taper bushings



BASICS ON TAPER BUSHINGS

These type of Bushings are used in a wide variety of applications, the most typical of them are used for the attachment of power transmission components to drive and driven shafts, as well as shafts into pulleys, sprockets, rollers and gears.

The tapered bushings by their wedge action exert a grip to the shaft

allowing a locking without any shaft deformation along with an ease of install-remove.

The most common types of Tapered Bushings are, Taper-Lock^{®1}, QD^{®2}, ST^{®3}, XT^{®4}.

TAPER LOCK TYPE BUSHINGS

These types of bushings characterize by having, no external flange, no external key, a nominal 8-degree taper angle, 1 11/16" per foot or 14,06 % taper, split through the entire bushing. Uses blind hex socket-head screws on the tapered outside diameter of the bushing. The screws drive the bushing into the bore of the component where has to be installed thus compressing the inner diameter of the bushing to the keyed shaft.

The clamping force over the standard bored-to-size that uses only a keyway and setscrew to lock onto the shaft is higher. The 8-degree taper design makes it easy to install and remove.

Aside from the general-purpose steel versions, they are available in Stainless Steel make, ideal for the food and beverage applications where the non-corrosion is a must.

MPTA[▼] Standard

Reference MPTA-B9i-2013 defines the general dimensions and tolerances for Taper-Lock detachable bushings and mating hubs.

Numbers 1008 up to 120100.

Section A-A

Bushings: 1008 - 3030

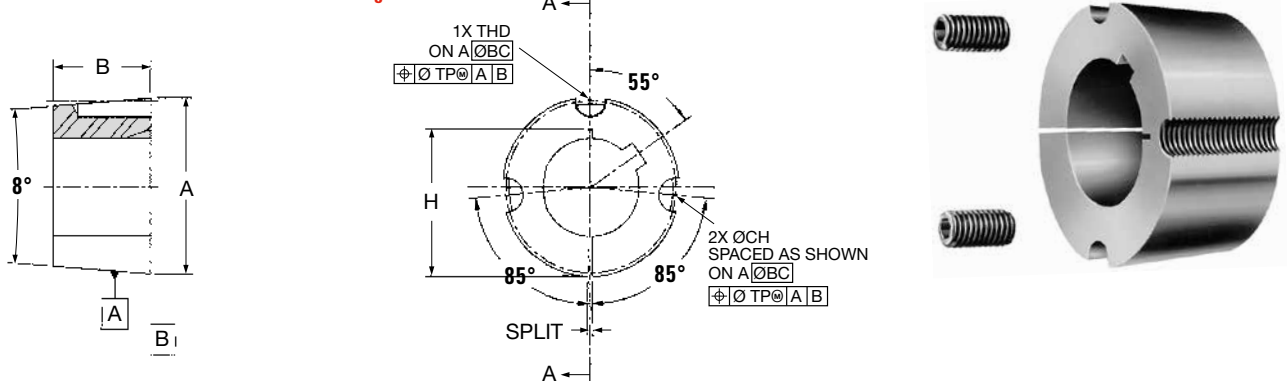

Bushings: 3525 - 5050

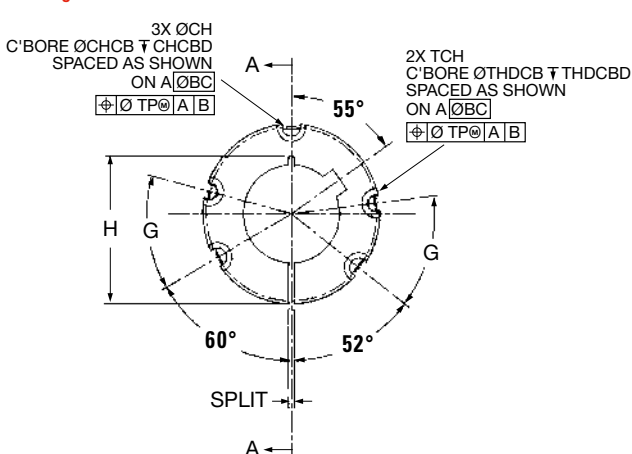

Bushing: 6050

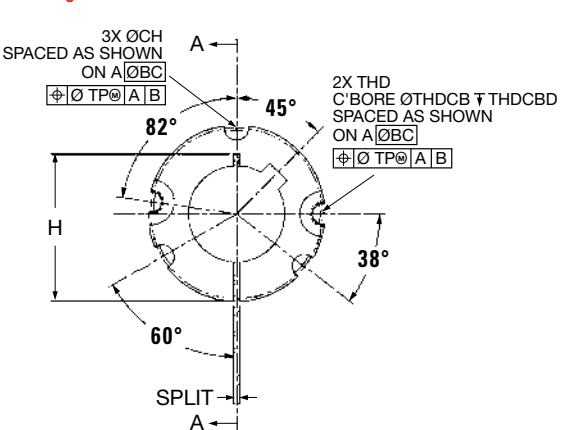

1. Taper-Lock is a registered trademark of Reliance Electric.
 2. QD which stands for Quick Disconnect is a registered trademark of Emerson Electric.
 3. ST stands for Split Taper after MST registered trademark of Martin Sprocket & Gear Inc.

4. XT stands for Extra Taper is registered trade mark of Emerson Electric.
 ▼ Mechanical Power Transmission Association. See page 20.

BUSHING	LARGE END DIA	LENGTH	HOLE SPACING	INSTALLATION SCREWS		BOLT CIRCLE	THREADED HOLES		CLEARANCE HOLES			SPLIT DIMENSIONS		
				Qty	Size		Qty	Size	Qty	Hole size	Depth min.	Min	Max	Depth max.
A	B	G												
1008	1,376 / 1,382	0,87	None	2	1/4-20NC X 1/2	1,33	1	1/4-20NC	2	17/64	15/32	0,04	0,13	1,16
1108	1,501 / 1,507	0,87	None	2	1/4-20NC X 1/2	1,45	1	1/4-20NC	2	17/64	15/32	0,04	0,13	1,25
1210	1,868 / 1,874	1,00	None	2	3/8-16NC X 5/8	1,75	1	3/8-16NC	2	25/64	1/2	0,04	0,13	1,41
1215	1,868 / 1,874	1,50	None	2	3/8-16NC X 5/8	1,75	1	3/8-16NC	2	25/64	1/2	0,04	0,13	1,41
1310	1,994 / 2,000	1,00	None	2	3/8-16NC X 5/8	1,88	1	3/8-16NC	2	25/64	1/2	0,04	0,13	1,53
1610	2,243 / 2,249	1,00	None	2	3/8-16NC X 5/8	2,13	1	3/8-16NC	2	25/64	1/2	0,04	0,13	1,81
1615	2,243 / 2,249	1,50	None	2	3/8-16NC X 5/8	2,13	1	3/8-16NC	2	25/64	31/64	0,04	0,13	1,81
2012	2,743 / 2,749	1,25	None	2	7/16-14NC X 7/8	2,63	1	7/16-14NC	2	29/64	45/64	0,04	0,13	2,25
2517	3,368 / 3,374	1,75	None	2	1/2-13NC X 1	3,25	1	1/2-13NC	2	33/64	7/8	0,04	0,13	2,84
2525	3,368 / 3,374	2,50	None	2	1/2-13NC X 1	3,25	1	1/2-13NC	2	33/64	7/8	0,04	0,13	2,84
3020	4,243 / 4,249	2,00	None	2	5/8-11NC X 1 1/4	4,00	1	5/8-11NC	2	41/64	1 7/64	0,04	0,13	3,50
3030	4,246 / 4,249	3,00	None	2	5/8-11NC X 1 1/4	4,00	1	5/8-11NC	2	41/64	1 7/64	0,04	0,13	3,56
3525	4,990 / 4,996	2,50	39°	3	1/2-13NC X 1 1/2	4,83	2	1/2-13NC	2	33/64	2 1/2	0,05	0,20	4,00
3535	4,990 / 4,996	3,50	39°	3	1/2-13NC X 1 1/2	4,83	2	1/2-13NC	2	33/64	2 1/2	0,05	0,20	4,00
4030	5,740 / 5,746	3,00	40°	3	5/8-11NC x 1 3/4	5,54	2	5/8-11NC	2	41/64	2 3/4	0,05	0,20	4,63
4040	5,740 / 5,746	4,00	40°	3	5/8-11NC x 1 3/4	5,54	2	5/8-11NC	2	41/64	2 3/4	0,05	0,20	4,63
4535	6,365 / 6,371	3,50	40°	3	3/4-10NC X 2	6,13	2	3/4-10NC	3	49/64	3 1/8	0,07	0,20	5,13
4545	6,365 / 6,371	4,50	40°	3	3/4-10NC X 2	6,13	2	3/4-10NC	3	49/64	3 1/8	0,07	0,20	5,13
5040	6,990 / 6,996	4,00	37°	3	7/8-9NC X 2 1/4	6,72	2	7/8-9NC	3	57/64	3 1/4	0,07	0,20	5,63
5050	6,990 / 6,996	5,00	37°	3	7/8-9NC X 2 1/4	6,72	2	7/8-9NC	3	57/64	3 1/4	0,07	0,20	5,63
6050	9,238 / 9,244	5,00	None	3	1 1/4-NC X 3 1/2	9,00	2	1 1/4-7NC	3	1 9/32	3 1/8	0,07	0,20	7,75
7060	10,238 / 10,244	6,00	None	4	1 1/4-7NC X 3 1/2	10,00	3	1 1/4-7NC	4	1 9/32	3 1/8	0,075	0,25	8,38
8065	11,238 / 11,244	6,50	None	4	1 1/4-7NC X 3 1/2	11,00	3	1 1/4-7NC	4	1 9/32	3 1/8	0,075	0,25	9,38
10085	14,738 / 14,744	8,50	None	4	1 1/2-6NC X 4	14,50	3	1 1/2-6NC	4	1 17/32	3 3/4	0,075	0,25	12,38
120100	17,243 / 17,249	10,00	None	6	1 1/2-6NC X 4	17,00	5	1 1/2-6NC	6	1 17/32	3 3/4	0,075	0,25	14,63

1. All dimensions in inches.
2. Installation screws OPSS= Oval Point Set Screw. SHCS= Socket Head Cap Screw. HHCS= Hex Head Cap Screw.
3. TAPER.LOCK® is a Registered Trade Mark of Baldor Electric Company.

Section A-A

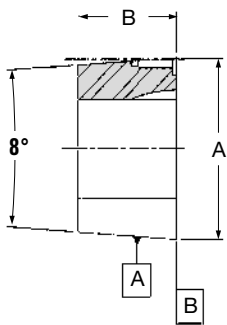

Bushings: 7060 - 10085

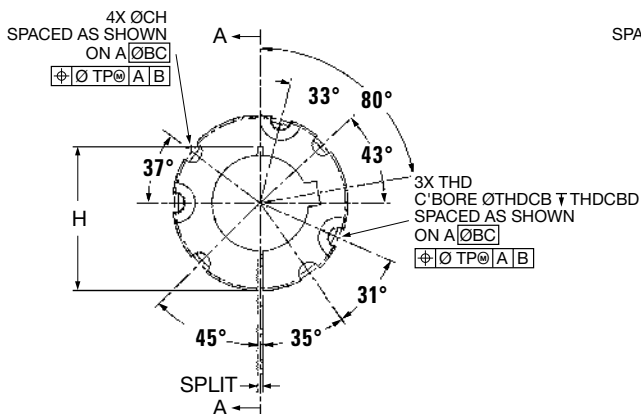

Bushings: 120100

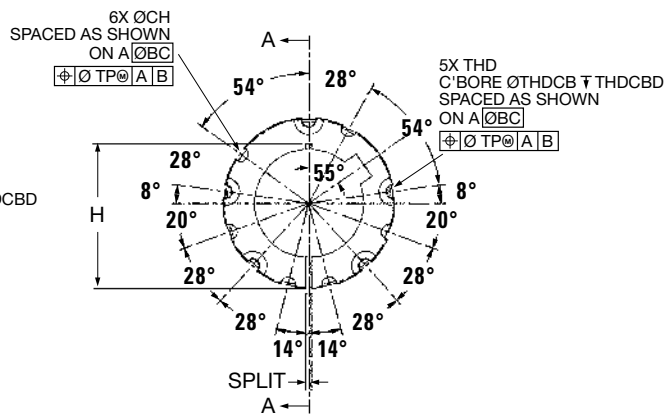

We offer an ample choice of bore sizes, both in inches, metric and a reborable supplied with a MPB. As far as materials, we offer versions in Steel, Ductile iron and Stainless Steel.

The tables ahead display the Standard sizes of the program, while other sizes and versions are available on MTO base.

TL-1008 through TL-5050 MPTA - ANSI

BUSHING	STANDARD BORES IN INCHES																				
TL-1008-X	3/8	7/16	1/2	9/16	5/8	11/16	3/4	13/16	7/8	15/16	1	1 1/16	1 1/8								
TL-1108-X	3/8	7/16	1/2	9/16	5/8	11/16	3/4	13/16	7/8	15/16	1	1 1/16	1 1/8								
TL-1210-X	1/2	9/16	5/8	11/16	3/4	13/16	7/8	15/16	1 1/16	1 1/8	1 3/16	1 1/4	1 5/16	1 3/8							
TL-1215-X	1/2	9/16	5/8	11/16	3/4	13/16	7/8	15/16	1 1/16	1 1/8	1 3/16	1 1/4	1 5/16	1 3/8							
TL-1610-X	1/2	9/16	5/8	11/16	3/4	13/16	7/8	15/16	1 1/16	1 1/8	1 3/16	1 1/4	1 5/16	1 3/8	1 7/16	1 1/2	1 5/8				
TL-1615-X	1/2	9/16	5/8	11/16	3/4	13/16	7/8	15/16	1 1/16	1 1/8	1 3/16	1 1/4	1 5/16	1 3/8	1 7/16	1 1/2	1 5/8				
TL-2012-X	3/4	13/16	7/8	15/16	1	1 1/16	1 1/8	1 3/16	1 1/4	1 5/16	1 3/8	1 7/16	1 1/2	1 5/8	1 3/4	1 7/8					
TL-2517-X	3/4	7/8	15/16	1	1 1/16	1 1/8	1 3/16	1 1/4	1 5/16	1 3/8	1 7/16	1 1/2	1 5/8	1 3/4	1 7/8	2	2 1/8	2 1/4	2 3/8	2 1/2	
TL-3020-X	1 1/4	1 5/16	1 3/8	1 7/16	1 1/2	1 5/8	1 3/4	1 7/8	2	2 1/8	2 1/4	2 3/8	2 1/2	2 5/8	2 3/4	2 7/8	3				
TL-3030-X	1 1/4	1 5/16	1 3/8	1 7/16	1 1/2	1 5/8	1 3/4	1 7/8	2	2 1/8	2 1/4	2 3/8	2 1/2	2 5/8	2 3/4	2 7/8	3				
TL-3525-X	1 1/2	1 5/8	1 3/4	1 7/8	2	2 1/8	2 1/4	2 3/8	2 1/2	2 5/8	2 3/4	2 7/8	3	3 1/8	3 1/4	3 3/8	3 1/2				
TL-3535-X	1 1/2	1 5/8	1 3/4	1 7/8	2	2 1/8	2 1/4	2 3/8	2 1/2	2 5/8	2 3/4	2 7/8	3	3 1/8	3 1/4	3 3/8	3 1/2				
TL-4030-X	1 3/4	1 7/8	2	2 1/8	2 1/4	2 3/8	2 1/2	2 5/8	2 3/4	2 7/8	3	3 1/8	3 1/4	3 3/8	3 1/2	3 3/4	4				
TL-4040-X	1 3/4	1 7/8	2	2 1/8	2 1/4	2 3/8	2 1/2	2 5/8	2 3/4	2 7/8	3	3 1/8	3 1/4	3 3/8	3 1/2	3 3/4	4				
TL-4545-X	2	2 1/8	2 1/4	2 3/8	2 1/2	2 5/8	2 3/4	2 7/8	3	3 1/8	3 1/4	3 3/8	3 1/2	3 3/4	4						
TL-5050-X	2 3/4	2 7/8	3	3 1/8	3 1/4	3 3/8	3 1/2	3 3/4	4	4 1/4	4 1/2	4 3/4	5								

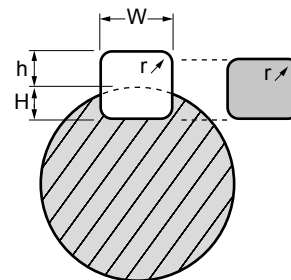

Other sizes available upon request.

Shaft Keyseat and Hub Keyway size

BUS-HING*	INCH BORE	WEIGHT**	
	3/8 to 9/16	0,27	0,12
TL-1008	5/8 to 7/8	0,21	0,10
	15/16 to 1 1/8	0,16	0,07
	1/2 to 9/16	0,33	0,15
TL-1108	5/8 to 7/8	0,27	0,12
	15/16 to 1 1/8	0,22	0,10
	1 1/16 to 1 1/4	0,17	0,08
	1/2 to 9/16	0,61	0,28
TL-1210	5/8 to 7/8	0,55	0,25
	15/16 to 1 1/4	0,49	0,22
	1/2 to 9/16	0,80	0,36
TL-1215	5/8 to 7/8	0,70	0,32
	15/16 to 1 1/4	0,60	0,27
	1/2 to 9/16	0,70	0,32
TL-1310	5/8 to 7/8	0,70	0,32
	15/16 to 1 1/4	0,60	0,27
	1 5/16 to 1 3/8	0,60	0,27
	1/2 to 9/16	0,90	0,41
	5/8 to 7/8	0,80	0,36
TL-1610	15/16 to 1 1/4	0,70	0,32
	1 5/16 to 1 3/8	0,70	0,32
	1 7/16 to 1 1/2	0,60	0,27
	1 9/16 to 1 5/8	0,50	0,23
	1/2 to 9/16	1,20	0,54
	5/8 to 7/8	1,10	0,50
TL-1615	15/16 to 1 1/4	1,00	0,45
	1 5/16 to 1 3/8	0,80	0,36
	1 7/16 to 1 1/2	0,70	0,32
	1 9/16 to 1 5/8	0,60	0,27
TL-2012	1/2 to 9/16	1,70	0,77

SHAFT DIAMETER D	WIDTH & HEIGHT W & H		SHAFT KEYSEAT				HUB KEYWAY				RADIUS r
			W		H		W		h		
			Over	To	Min	Max	Min	Max	Min	Max	
1/4	1/2	1/8	0,124	0,125	0,072	0,078	0,125	0,126	0,060	0,066	0,010
1/2	3/4	3/16	0,187	0,188	0,107	0,113	0,188	0,189	0,088	0,094	0,010
3/4	1	1/4	0,249	0,250	0,142	0,148	0,250	0,251	0,115	0,121	0,010
1	1 1/4	5/16	0,311	0,312	0,177	0,183	0,312	0,313	0,142	0,148	0,010
1 1/4	1 1/2	3/8	0,374	0,375	0,213	0,219	0,375	0,376	0,169	0,175	0,010
1 1/2	1 3/4	7/16	0,437	0,438	0,248	0,254	0,438	0,439	0,197	0,203	0,020
1 3/4	2	1/2	0,499	0,500	0,283	0,289	0,500	0,501	0,224	0,230	0,020
2	2 1/2	5/8	0,624	0,625	0,354	0,360	0,625	0,626	0,278	0,284	0,020
2 1/2	3	3/4	0,749	0,750	0,424	0,430	0,750	0,751	0,333	0,339	0,020
3	3 1/2	7/8	0,874	0,875	0,495	0,501	0,875	0,876	0,387	0,393	0,062
3 1/2	4	1	0,999	1,000	0,566	0,572	1,000	1,001	0,442	0,448	0,062
4	5	1 1/4	1,248	1,250	0,707	0,713	1,250	1,252	0,551	0,557	0,062
5	6	1 1/2	1,498	1,500	0,848	0,854	1,500	1,502	0,661	0,667	0,062

All sizes in inches.

BUS-HING*	INCH BORE	WEIGHT**		BUS-HING*	INCH BORE	WEIGHT**		BUS-HING*	INCH BORE	WEIGHT**	
		lbs	Kgs			lbs	Kgs			lbs	Kgs
	5/8 to 7/8	1,60	0,73	TL-2517	1 13/16 to 2 1/4	2,40	1,09		1 13/16 to 2 1/4	5,30	2,40
	15/16 to 1 1/4	1,50	0,68		2 5/16 to 2 1/2	1,90	0,86	TL-3020	2 5/16 to 2 3/4	4,50	2,04
	1 5/16 to 1 3/8	1,40	0,64		3/4 to 7/8	4,90	2,22		2 13/16 to 3	3,90	1,77
TL-2012	1 7/16 to 1 3/4	1,20	0,54		15/16 to 1 1/4	4,70	2,13		15/16 to 1 1/4	9,20	4,17
	1 13/16 to 1 7/8	1,00	0,45	TL-2525	15/16 to 1 3/8	4,50	2,04		1 5/16 to 1 3/8	8,90	4,04
	1 15/16 to 2	1,00	0,45		1 7/16 to 1 3/4	4,20	1,91	TL-3030	1 7/16 to 1 3/4	8,60	3,90
	1/2 to 9/16	3,50	1,59		1 13/16 to 2 1/4	3,30	1,50		1 13/16 to 2 1/4	7,60	3,45
	5/8 to 7/8	3,40	1,54		2 5/16 to 2 1/2	2,50	1,13		2 5/16 to 2 3/4	6,20	2,81
TL-2517	15/16 to 1 1/4	3,30	1,50		15/16 to 1 1/4	6,50	2,95		2 13/16 to 3	5,00	2,27
	1 5/16 to 1 3/8	3,20	1,45	TL-3020	1 5/16 to 1 3/8	6,30	2,86				
	1 7/16 to 1 3/4	3,00	1,36		1 7/16 to 1 3/4	6,00	2,72				

* All dimensions in inches.
** Approximate.

TL-SS 1108 through TL-SS 2012 MPTA - ANSI

Made out of 300-series Stainless Steel, presents high resistance to corrosion, resistance and durability. Used mainly in applications of food processing and water industry, wastewater, agriculture and

in general for any application where anti corrosion combining with high strenght are needed.

REFERENCE IMPERIAL	STANDARD BORES IN INCHES																						
TL-SS-1008-X	1/2	9/16	5/8	11/16	3/4	13/16	7/8	1															
TL-SS-1108-X	1/2	9/16	5/8	11/16	3/4	13/16	7/8	15/16	1	1 1/16	1 1/8												
TL-SS-1210-X	1/2	9/16	5/8	11/16	3/4	13/16	7/8	15/16	1	1 1/16	1 1/8	1 3/16	1 1/4										
TL-SS-1215-X	1/2	9/16	5/8	11/16	3/4	13/16	7/8	15/16	1	1 1/16	1 1/8	1 3/16	1 1/4										
TL-SS-1610-X	1/2	9/16	5/8	11/16	3/4	13/16	7/8	15/16	1	1 1/16	1 1/8	1 3/16	1 1/4	1 5/16	1 3/8	1 1/2	1 9/16	1 5/8					
TL-SS-1615-X	1/2	9/16	5/8	11/16	3/4	13/16	7/8	15/16	1	1 1/16	1 1/8	1 3/16	1 1/4	1 5/16	1 3/8	1 1/2	1 9/16	1 5/8					
TL-SS-2012-X	1/2	9/16	5/8	11/16	3/4	13/16	7/8	15/16	1	1 1/16	1 1/8	1 3/16	1 1/4	1 3/8	1 7/16	1 1/2	1 9/16	1 5/8	1 11/16	1 3/4	1 13/16	1 15/16	2

All dimensions in inches. Other dimensions available.

REFERENCE	STANDARD BORES IN METRIC															
TL-SS-1008-X	10	11	12	14	16	18	19	20	22	24	25					
TL-SS-1108-X	10	11	12	14	16	18	19	20	22	24	25	28				
TL-SS-1210-X	10	11	12	14	16	18	19	20	22	24	25	28	30	32		
TL-SS-1215-X	11	12	14	16	18	19	20	22	24	25	28	30	32			
TL-SS-1610-X	14	16	18	19	20	22	24	25	28	30	32	35	38	40	42	
TL-SS-1615-X	14	16	18	19	20	22	24	25	28	30	32	35	38	40	42	
TL-SS-2012-X	18	19	20	22	24	25	28	30	32	35	38	40	42	45	48	50

All dimensions in mm. Other dimensions available.



TAPER LOCK TYPE WELD-ON HUBS

Used for insertion and welding to plate or disc like applications so to produce type B Sprockets, Pulleys, and any other without hub protrusion. Manufactured to accept Taper Lock Bushings, are available in two versions, namely the S and the W. The type S, for short,

provides a shorter LTB (Length Through Bore) while type W with a shouldered outer diameter provides a very convenient design of welding hubs into fan rotors, pulleys, plate sprockets, agitators and other devices which must be firmly fastened to the shaft.

Type S

REFERENCE*	BUSH NO	BORE MAX	DIA A	DIA G	DIA J	WIDTH B	WIDTH C	WIDTH D	LBS	KGS
TL-S16-4	1610	1 5/8	3	2 7/8	2 1/4	1	11/40	29/40	0,90	0,41
TL-S16S-6	1610	1 5/8	3	2 7/8	2 1/4	1	9/20	11/20	0,90	0,41
TL-S20S-6	2012	2	3 5/8	3 7/16	2 3/4	1 1/4	9/20	4/5	1,80	0,82
TL-S20S-8	2012	2	3 5/8	3 7/16	2 3/4	1 1/4	53/93	17/25	1,40	0,64
TL-S25S-6	2517	2 1/2	4 1/4	4 1/8	3 3/8	1 3/4	9/20	1 3/10	2,60	1,18
TL-S25-8	2517	2 1/2	4 1/4	4 1/8	3 3/8	1 3/4	13/23	1 5/27	2,60	1,18
TL-S25-10	2517	2 1/2	4 1/4	4 1/8	3 3/8	1 3/4	50/73	1 5/77	2,50	1,13
TL-S25-16	2517	2 1/2	4 1/4	4 1/8	3 3/8	1 3/4	1 1/11	33/50	2,40	1,09
TL-S30-10	3020	3	5 1/4	5 1/8	4 1/4	2	27/40	1 13/40	4,30	1,95
TL-S30-16	3020	3	5 1/4	5 1/8	4 1/4	2	1 1/11	81/89	4,20	1,91
TL-S35	3535	3 1/2	6 1/2	6 3/8	5	3 1/2	1 4/25	2 17/50	12,80	5,81

* All measures in inches.

Type S

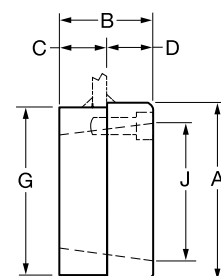

Type W

REFERENCE*	BUSH NO	BORE MAX	DIA A	DIA G	DIA J	DIA K	WIDTH B	WIDTH C	WIDTH D	WIDTH F	DIA H	LBS	KGS
TL-W12	1215	1 1/4	2 7/8	2 1/2	1 7/8	2 5/8	1 1/2	3/8	5/8	3/8	2 3/8	1,30	0,59
TL-W16	1615	1 5/8	3 1/4	2 7/8	2 1/4	3	2	3/8	5/8	3/8	2 3/4	1,50	0,68
TL-W25	2517	2 1/2	4 7/8	4 3/8	3 3/8	4 5/8	1 3/4	1/2	3/4	3/8	4 1/4	4,00	1,81
TL-W30	3030	3	5 1/2	5 1/8	4 1/4	5	3	3/4	3/4	3/8	4 13/16	8,60	3,90
TL-W35	3535	3 1/2	6 3/4	6 1/4	5	6	4	1 1/4	1	3/8	5 15/16	15,00	6,81
TL-W40	4040	4	7 3/4	7 1/4	5 3/4	7	4	1 1/2	1	3/8	6 7/8	29,00	13,16
TL-W45	4545	4 1/2	8 3/4	8	6 3/8	8	5	1 3/4	1	3/8	7 5/8	42,00	19,06
TL-W50	5050	5	9 1/2	8 3/4	7	8 3/4	5	1 3/4	1	3/8	8 3/8	57,00	25,86

* All measures in inches.

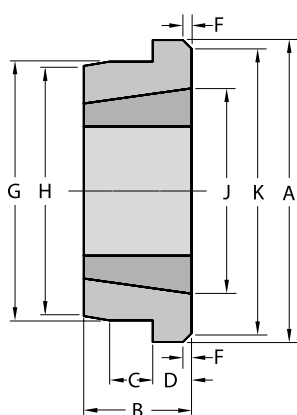

Type W
Type WM



Type WM

REFERENCE*	BUSH NO	DIA A	DIA G	WIDTH B	WIDTH C	WIDTH D
TL-1210-WM	1210	70	60	25	10	9
TL-1610-WM	1610	83	70	25	10	9
TL-1615-WM	1615	83	70	38	11	16
TL-2012-WM	2012	95	90	32	12	12
TL-2517-WM	2517	127	110	44	13	19
TL-3020-WM	3020	152	130	50	15	20
TL-3030-WM	3030	152	130	76	19	25
TL-3535-WM	3535	184	155	87	25	32
TL-4040-WM	4040	225	195	102	32	32
TL-4545-WM	4545	254	220	114	38	38
TL-5050-WM	5050	276	242	127	38	38

* All measures in mm.

REBORABLE TAPER LOCK TYPE BUSHINGS

These bushings are available in MPB (Minimum Plain Bore) without keyways in three versions, Steel for TL-1008 to TL-3020, Stainless Steel

for TL-1008 to TL-3020 and Ductile Iron for TL-3030 to TL-8065. To make the remachining easier they are delivered without the sawsplit.

REFERENCE*	MATERIAL	STEEL	DUCTILE IRON	STAINLESS STEEL
		Bore	Bore	Bore
TL-1008	Steel	1/2		
TL-1108	Steel	1/2		
TL-1210	Steel	1/2		
TL-1215	Steel	1/2		
TL-1310	Steel	1/2		
TL-1610	Steel	1/2		
TL-1615	Steel	1/2		
TL-2012	Steel	1/2		
TL-2517	Steel	1		
TL-2525	Steel	1 7/16		
TL-3020	Steel	1 7/16		
TL-1008	Stainless Steel			1/2
TL-1108	Stainless Steel			1/2
TL-1210	Stainless Steel			1/2
TL-1215	Stainless Steel			1/2
TL-1310	Stainless Steel			1/2
TL-1610	Stainless Steel			1/2
TL-1615	Stainless Steel			1/2
TL-2012	Stainless Steel			1/2
TL-2517	Stainless Steel			1
TL-2525	Stainless Steel			
TL-3020	Stainless Steel			7/8
TL-3030	Ductile Iron		15/16	
TL-3525	Ductile Iron		1 3/16	
TL-3535	Ductile Iron		1 7/16	
TL-4030	Ductile Iron		1 15/16	
TL-4040	Ductile Iron		1 15/16	
TL-4535	Ductile Iron		2 7/16	
TL-4545	Ductile Iron		2 7/16	
TL-5040	Ductile Iron		2 15/16	
TL-5050	Ductile Iron		2 15/16	
TL-6050	Ductile Iron		3 7/16	
TL-7060	Ductile Iron		3 15/16	
TL-8065	Ductile Iron		4 7/16	

* All measures in inches. Other sizes available. Metric sizes available.



Hints on Taper-Lock Type Bushings. Installing & Removal

Sprockets and pulleys are the typical use of the Taper-Lock. The mounting procedure starts with a thorough cleaning of the shaft, the hub bore of any dirt and the removal of burrs if any.

The hub has to be inserted into the sprocket or pulley. The installation drills in the hub are tapped in the sprocket or pulley side and not in the bush side. The removal holes are tapped in the bush side but not in the sprocket or pulley side.

Once the hub has been inserted and aligned, the cap screws have to be lightly tightened to the half tapped holes in the sprocket or pulley as an assembly.

Position after the assembly in the shaft aligning its keyway to keyshaft, allowing a slight axial movement. Tighten the capscrews to half of the torque indicated in table below so that the hub will be completely seated.

Check the alignment and tighten the cap screws to the full recommended torque.

After the first run, double check the torque and adjust as directed. To remove the assembly, loosen the installing cap screws and insert the cap screws in the removal holes to break the cone grip.

● Removal Holes



1008 to 3020

○ Installation Holes



1008 to 3020



7060

TAPER BUSHING	CAP SCREWS*		TORQUE
	Size	Qty	
TL-1008	1/4-20NC X 1/2	2	4,60
TL-1108	1/4-20NC X 1/2	2	4,60
TL-1210	3/8-16NC X 5/8	2	14,60
TL-1610	3/8-16NC X 5/8	2	14,60
TL-1015	3/8-16NC X 5/8	2	14,60
TL-2012	7/16-14NC X 7/8	2	23,30
TL-2517	1/2-13NC X 1	2	35,80
TL-3020	5/8-11NC X 1 1/4	2	66,70
TL-3525	1/2-13NC X 1 1/2	3	83,30
TL-3535	1/2-13NC X 1 1/2	3	83,30
TL-4030	5/8-11NC x 1 3/4	3	141,70
TL-4040	5/8-11NC x 1 3/4	3	141,70
TL-4535	3/4-10NC X 2	3	204,20
TL-4545	3/4-10NC X 2	3	204,20
TL-5050	7/8-9NC X 2 1/4	3	258,30
TL-6050	1 1/4-NC X 3 1/2	3	651,70
TL-7060	1 1/4-7NC X 3 1/2	4	651,70

* All dimensions in inches.

QD TYPE BUSHINGS

QD, a short for Quick Detachable bushings are characterized by having, an external flange, no external key, a nominal 3/4" per foot taper i.e. 1° 47' 17.5" (6,25%), split through both flange and taper, conventional and reverse mount capacity.

The taper is about half the angle of other types of bushings what gives a higher clamping force than other types of bushings.

The MPTA Standard Reference MPTA-B6c-2016, extension of MPTA-B6i-2010, provides the general dimensions and tolerances for inch and metric for quick detachable bushings and mating hubs.



MPTA Standard

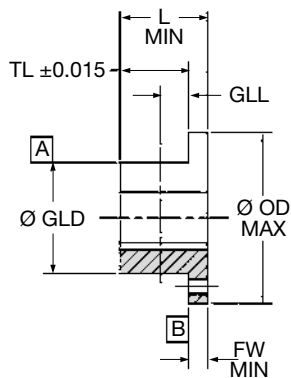

Type 2: Bushings M thru W

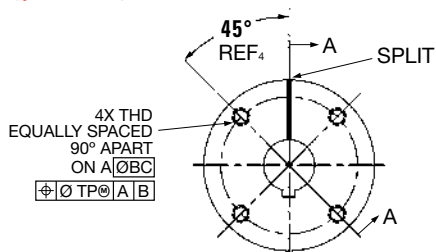

Type 1: Bushings JA thru J

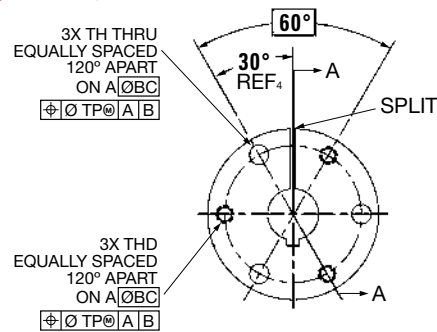

Type 3: Bushing S

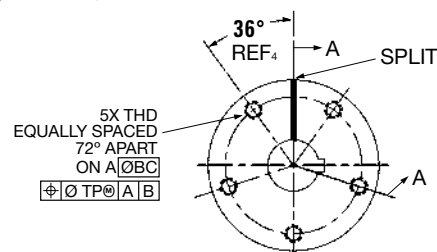

JA through S. MPTA - ANSI

BUSHING		GAGE LINE		FLANGE WIDTH	OUTSIDE DIAMETER	TAPER LENGTH	BUSHING LENGTH	THREADED HOLE THREAD SIZE	THRU HOLE Min diameter	DEPTH BOLT CIRCLE	MIN TRUE POSITION
		Diameter	Diameter								
Ref	Type	GLD	GLL	FW	OD	TL	L	THD	TH	Dimeter BC	TP
JA	1	1,3750	0,1860 / 0,2340	0,30	2,02	0,56	0,80	#10-24 UNC-2B	0,2189	1,6560	0,007
SH	1	1,8710	0,2120 / 0,2740	0,36	2,70	0,81	1,17	1/4-20 UNC-2B	0,2813	2,2500	0,007
SDS	1	2,1875	0,2320 / 0,2980	0,42	3,20	0,88	1,30	1/4-20 UNC-2B	0,3125	2,6875	0,007
SD	1	2,1875	0,2220 / 0,2980	0,42	3,20	1,38	1,80	1/4-20 UNC-2B	0,3125	2,6875	0,007
SK	1	2,8125	0,2580 / 0,3770	0,48	3,89	1,25	1,67	5/16-18 UNC-2B	0,3438	3,3125	0,007
SF	1	3,1250	0,2680 / 0,3770	0,48	4,64	1,44	1,98	3/8-16 UNC-2B	0,4375	3,8750	0,015
E	1	3,8340	0,2780 / 0,3770	0,73	6,02	1,88	2,61	1/2-13-UNC-2B	0,5625	5,0000	0,015
F	1	4,4375	0,3750 / 0,4710	0,80	6,64	2,75	3,61	9/16-12 UNC-2B	0,625	5,6250	0,015
J	1	5,1484	0,3750 / 0,4710	0,98	7,27	3,50	4,48	5/8-11 UNC-2B	0,6875	6,2500	0,015
M	2	6,5000	0,3750 / 0,4710	1,23	9,14	5,50	6,73	3/4-10 UNC-2B	0,8125 (3)	7,8750	0,015
N	2	7,0000	0,3750 / 0,4710	1,48	10,02	6,63	8,11	7/8-9 UNC-2B	0,9375 (3)	8,5000	0,015
P	2	8,2500	0,3750 / 0,4711	1,73	11,17	7,63	9,36	1-8 UNC-2B	1,0625 (3)	10,0000	0,030
W	2	10,4375	0,5000 / 0,6280	1,98	15,02	9,38	11,36	1 1/8-7UNC-2B	1,0938 (3)	12,7500	0,030
S	2	12,2500	0,7500 / 0,8780	3,23	17,77	12,50	15,73	1 1/4-7UNC-2B	1,3125 (3)	15,0000	0,030

1. All dimensions in inches.

2. Taper angle 1° 47' 24" ± 2' (per side) or 80% contact with on-size ring gage.

3. Only required for reverse mount.

JA through S. MPTA - METRIC

BUSHING		GAGE LINE		FLANGE WIDTH	OUTSIDE DIAMETER	TAPER LENGTH	BUSHING LENGTH	THREADED HOLD THREAD SIZE	THRU HOLE Min diameter	DEPTH BOLT CIRCLE	MIN TRUE POSITION
		Diameter	Diameter								
Ref	Type	GLD	GLL	FW	OD	TL	L	THD	TH	Dimeter BC	TP
JA	1	34,9300	4,72 / 5,94	7,62	51,31	14,22	20,32	M5 X 0,8	5,56	42,0600	0,18
SH	1	47,5200	5,38 / 6,96	9,14	68,58	20,57	29,73	M6 X 1	7,15	57,1500	0,18
SDS	1	55,5600	5,89 / 7,57	10,67	81,28	22,35	33,02	M6 X 1	7,94	68,2600	0,18
SD	1	55,5600	5,64 / 7,57	10,67	81,28	35,05	45,72	M6 X 1	7,94	68,2600	0,18
SK	1	71,4400	6,55 / 9,56	12,19	98,91	31,75	42,42	M8 X 1,25	8,73	84,1400	0,18
SF	1	79,3800	6,81 / 9,56	12,19	117,86	36,58	50,29	M10 X 1,5	11,11	98,4300	0,38
E	1	97,3800	7,06 / 9,56	18,54	152,91	47,75	66,29	M12 X 1,75	14,29	127,0000	0,38
F	1	112,7100	9,53 / 11,96	20,32	168,66	69,85	91,69	M14 X 2	15,88	142,8800	0,38
J	1	130,7700	9,53 / 11,96	24,89	184,66	88,90	113,79	M16 X 2	17,46	158,7500	0,38
M	2	165,1000	9,53 / 11,96	31,24	232,16	139,70	170,94	M20 X 2,5	20,64	200,0300	0,38
N	2	177,8000	9,53 / 11,96	37,59	254,51	168,40	205,99	M22 X 2,5	23,81	215,9000	0,015
P	2	209,5500	9,53 / 11,96	43,94	298,96	193,80	237,74	M24 X 3	26,99	254,0000	0,760
W	2	265,1100	12,7 / 15,95	50,29	381,51	238,25	288,54			323,8500	0,760
S	3	307,9800	19,05 / 22,30	82,04	451,36	317,50	399,54			381,0000	0,760

1. All dimensions in inches.

2. Taper angle 1° 47' 24" ± 2' (per side) or 80% contact with on-size ring gage.

BUSHING	NUMBER OF BOLTS	THREAD SIZE	BOLT LENGTH	MIN THREAD LENGTH	REVERSE MOUNT LENGTH	REVERSE MOUNT MIN THREAD
		B THD	BL	BTL	BL	BTL
JA	3	# 10-24 UNC-2B	1,00	1,00	1,00	1,00
SH	3	1/4-20 UNC-2B	1,38	1,13	1,13	1,13
SDS	3	1/4-20 UNC-2B	1,38	1,13	1,13	1,13
SD	3	1/4-20 UNC-2B	1,88	1,38	1,38	1,38
SK	3	5/16-18 UNC-2B	2,00	1,50	1,50	1,50
SF	3	3/8-16 UNC-2B	2,00	1,50	1,50	1,50
E	3	1/2-13 UNC-2B	2,75	1,88	1,88	1,88
F	3	9/16-12 UNC-2B	3,63	2,75	2,75	2,75
J	3	5/8-11 UNC-2B	4,50	3,38	3,38	3,38
M	4	3/4-10 UNC-2B	6,75	2,00	3,00	2,00
N	4	7/8-9 UNC-2B	8,00	2,25	3,50	2,25
P	4	1-8 UNC-2B	9,50	2,50	4,00	2,50
W	4	1 1/8-7 UNC-2B	11,50	2,75	4,50	2,75
S	5	1 1/4-7 UNC-2B	15,50	4,50	7,00	4,50

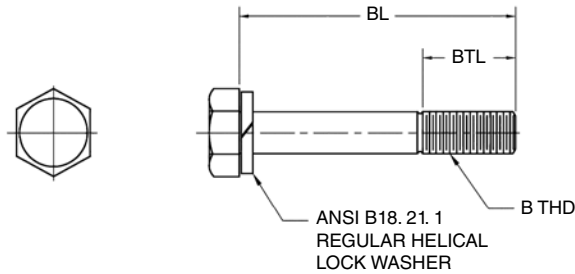

BUSHING	NUMBER OF BOLTS	THREAD SIZE	BOLT LENGTH	MIN THREAD LENGTH	REVERSE MOUNT LENGTH	REVERSE MOUNT MIN THREAD
		B THD	BL	BTL	BL	BTL
JA	3	M5 X 0,8	25,00	25,40	25,40	25,40
SH	3	M6 X 1	35,00	28,70	28,70	28,70
SDS	3	M6 X 1	35,00	28,70	28,70	28,70
SD	3	M6 X 1	50,00	35,10	35,10	35,10
SK	3	M6 X 1,25	50,00	38,10	38,10	38,10
SF	3	M10 X 1,5	50,00	38,10	38,10	38,10
E	3	M12 X 1,75	70,00	47,80	47,80	47,80
F	3	M14 X 2	100,00	69,90	69,90	69,90
J	3	M16 X 2	120,00	85,90	85,90	85,90
M	4	M20 X 2,5	170,00	50,80	76,20	50,80
N	4	M22 X 2,5	200,00	57,20	88,90	57,20
P	4	M24 X 3	240,00	63,50	101,60	63,50
W	4					
S	5					

Our program covers the most models of the MPTA-B6c-2016 Standard, with a wide choice of inch and metric bores for a wide variety of industrial applications. As far as materials are concerned, we offer

the range in Steel and Stainless Steel.

The tables ahead display the Standard sizes of the program while other sizes and execution materials are available on MTO base.

QD TYPE*	A	B	D	E	F	G	L	BOLT CIRCLE	CAP SCREWS		WEIGHT	
									Size	Qty	lbs	Kgs
TL-JA	3/8	1 3/8	2	11/16	9/16	1/8	1	1 65/99	10-24 UNC x 1	3	0,900	0,408
TL-SH	7/16	1 27/31	2 11/16	7/8	13/16	1/8	1 1/4	2 1/4	1/4-20 UNC x 1 3/8	3	1,000	0,454
TL-SDS	1/2	2 3/16	3 3/16	7/8	3/4	1/8	1 3/8	2 11/16	1/4-20 UNC x 1 3/8	3	1,000	0,454
TL-SD	1/2	2 3/16	3 3/16	15/16	1 1/4	1/8	1 13/16	2 11/16	1/4-20 UNC x 1 3/8	3	1,500	0,681
TL-SK	9/16	2 13/16	3 7/8	1 3/8	1 1/4	1/8	1 1/8	3 5/16	5/16 -18 UNC x 2	3	2,000	0,907
TL-SF	9/16	3 1/8	4 5/8	1 1/2	1 1/4	1/8	2	3 7/8	3/8-16 UNC x 2	3	3,000	1,361
TL-E	3/4	3 5/6	6	1 7/8	1 5/8	1/8	2 5/8	5	1/2-13 UNC x 2 3/4	3	10,000	4,537
TL-F	13/16	4 7/16	6 5/8	2 13/16	2 1/2	3/16	3 5/8	5 5/8	9/16-12 UNC x 3 5/8	3	11,500	5,218
TL-J	1	5	7	3 1/2	3 3/16	3/16	4 1/2	6 1/4	5/8-11 UNC x 4 1/2	3	18,000	8,167
TL-M	1 1/4	6 1/2	9	5 1/2	5 3/16	3/16	6 3/4	7 7/8	3/4-10 UNC x 6 3/4	4	37,000	16,787
TL-N	1 1/2	7	10 1/4	6 5/8	6 1/4	1/4	8 1/8	8 1/2	7/8-9 UNC x 8	4	57,000	25,862
TL-P	1 3/4	8 1/4	11 3/4	7 5/8	7 1/4	1/4	9 3/8	10	1-8 UNC x 9 1/2	4	120,000	54,446
TL-W	2	10	15	9 3/8	9	1/4	11 3/8	12 3/4	1 1/8-7 UNC x 11 1/2	4	250,000	113,429
TL-S	3 1/4	12 1/8	17 3/4	12 1/2		3/8	15 3/4	15	1 1/4-7 UNC x 15 1/2	5	400,000	181,486

* All dimensions in inches.

QD TYPE*	BORES		HUB KEYWAY
	from	to	
TL-JA	3/8	7/16	none
	1/2	1	standard
	1 1/16	1 1/8	1/4 X 1/16
	13/16		1/4 X 1/16
TL-SH	1 1/4		none
	1/2	1 3/8	standard
	1 7/16	1 1/2	3/8 X 1/16
	1 9/16	1 5/8	3/8 X 1/16
TL-SDS	1 11/16		none
	1/2	1 11/16	standard
	1 3/4		3/8 X 1/8
	1 13/16		1/2 X 1/8
TL-SD	1 7/8	1 15/16	1/2 X 1/16
	2		none
	1/2	1 11/16	standard
	1 3/4		3/8 X 1/8
TL-SK	1 13/16		1/2 X 1/8
	1 7/8		1/2 X 1/16
	1 15/16		1/2 X 1/16
	2		none
TL-SF	1/2	2 1/8	standard
	2 3/16	2 1/4	5/8 X 1/8
	2 5/16	2 1/2	5/8 X 1/16
	2 9/16	2 5/8	none

QD TYPE*	BORES		HUB KEYWAY
	from	to	
TL-SF	1/2	2 1/4	standard
	2 5/16	2 1/2	5/8 X 3/16
	2 9/16	2 3/4	5/8 X 1/16
	2 13/16	2 7/8	3/4 X 1/16
TL-E	2 15/16		3/4 X 3/97
	7/8	2 7/8	standard
	2 15/16	3 1/4	3/4 X 1/8
	3 3/8	3 1/2	7/8 X 3/16
TL-F	3 5/16		7/8 X 1/8
	1	3 5/16	standard
	3 3/8	3 3/4	7/8 X 3/16
	3,875	3,938	1 X 1/8
TL-J	4		none
	1 1/4	3 3/4	standard
	3 13/16	4 1/2	1 X 1/8
	2	4 3/4	standard
TL-M	4 13/16	5 1/2	1 X 1/4
	2 7/16	5	standard
	5 1/8	5 1/2	1 1/4 X 1/4
	5 9/16	6	1 1/2 X 1/4
TL-N	2 15/16	5 15/16	standard
	6	6 1/2	1 1/2 X 1/4
	6 9/16	7	1 3/4 X 1/8
	4	7 1/2	standard
TL-P	7 9/16	8 1/2	2 X 2 1/2
	4	7 1/2	standard
	7 9/16	8 1/2	2 X 2 1/2
	7 9/16	8 1/2	2 X 2 1/2

* All dimensions in inches.

QD TYPE*	BORES	KEY SIZE
	32, 35	10 x 8
TL-SDS	24,25,28,30	8 x 7
	32,35,38	10 x 8
TL-SD	40,42	12 x 8
	24,25,28,30	8 x 7
TL-SK	32,35,38	10 x 8
	40,42	12 x 8
TL-SF	24,25,28,30,32,35,38	8 x 7
	32,35,38	10 x 8
TL-E	40,42	12 x 8
	48,50	14 x 9
TL-F	55	16 x 10
	28,3	8 x 7
TL-J	32,35,38	10 x 8
	40,42	12 x 8
TL-M	48,50	14 x 9
	55	16 x 10
TL-N	60	18 x 11
	35,38	10 x 8
TL-P	40,42	12 x 8
	48,5	14 x 9
TL-W	55	16 x 10
	60,65	18 x 11
	70,75	20 x 12

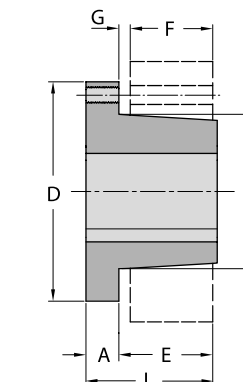

QD TYPE*	BORES	KEY SIZE
TL-F	48,50	14 x 9
	55	16 x 10
	60,65	18 x 11
	70,75	20 x 12
TL-J	80,85	22 x 14
	90	25 x 14
	50	14 x 9
	55	16 x 10
TL-S	60,65	18 x 11
	70,75	20 x 12
	80,85	22 x 14
	90,95	25 x 14
	100	28 x 16

* All dimensions in mm.



QD Type Weld-On Hubs

Used for insertion and welding to produce B type sprockets, pulleys and other applications without hub protrusion. Manufactured to

accept QD Type Bushings according to the drills.

WELD-ON QD TYPE*	QD TYPE	DRILL TYPE	D	L	L1	P	THREAD SIZE THD	COUNTER BORE		THROUGH HOLE dia TH	BOLT CIRCLE dia BC	WEIGHT		MOUNTING SYSTEM
								Min dia	depth			lbs	Kgs	
TL-JA-A	JA	1	2,250	0,56			#10-24 UNC	NONE	NONE	0,2190	1,6560	0,40	0,18	
TL-SH-A	SH	1	3,000	0,81			1/4-20 UNC	0,2813	0,310	0,2813	2,2500	1,00	0,45	
TL-SDS-A	SDS	1	3,500	0,75			1/4-20 UNC	0,3125	0,250	0,3125	2,6875	1,20	0,54	
TL-SD-A	SD	1		1,25			1/4-20 UNC	0,3125	0,750	0,3125	2,6875	3,00	1,36	Standard
TL-SK-A	SK	1	4,375	1,25			5/16-18 UNC	0,3438	0,620	0,3438	3,3125	3,00	1,36	or
TL-SF-A	SF	1	5,000	1,25			3/8-16 UNC	0,4375	0,560	0,4375	3,8750	4,00	1,81	Reverse
TL-E-A	E	1	6,250	1,63			1/2-13 UNC	0,5625	0,750	0,5625	5,0000	9,00	4,08	
TL-F-A	F	1	7,000	2,50			9/16-12 UNC	0,6250	1,500	0,6250	5,6250	16,00	7,26	
TL-J-A	J	1	7,750	3,19			5/8-11 UNC	0,6875	2,060	0,6875	6,2500	22,50	10,21	
TL-M-A	M	2	9,500	5,19	3,563	9,25	3/4-10 UNC	0,8125	3,940	0,8125	7,8750	50,00	22,68	
TL-N-A	N	2	10,500	6,25	4,500	10,25	7/8-UNC	0,9375	4,810	0,9375	8,5000	75,00	34,02	
TL-P-A	P	2	13,000	7,25			1-8 UNC	1,1250	6,560	1,1250	10,0000	155,00	70,31	Standard
TL-W-A	W	2	15,500	9,00			1 1/16-7 UNC	1,2540	7,190	1,2500	12,7500	300,00	136,08	
TL-S-A	S	3	19,500	12,00	7,500	18,75	1 1/4-UNC	1,3750	9,250	1,3750	15,0000	558,00	253,11	

* All measures in inches.

Type A

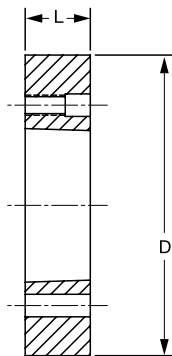

Type 1 Drilling

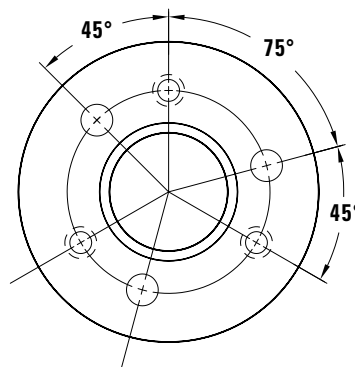

Type SA

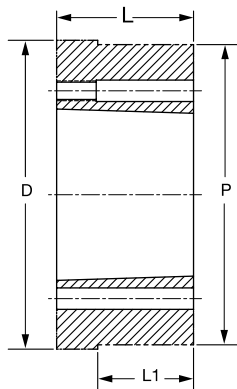

Type 2 Drilling

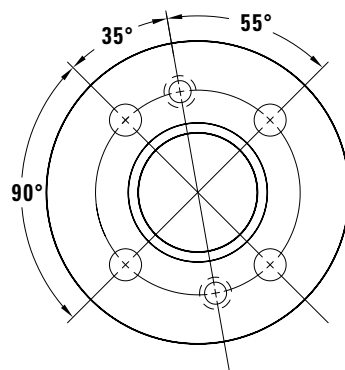

Type 3 Drilling

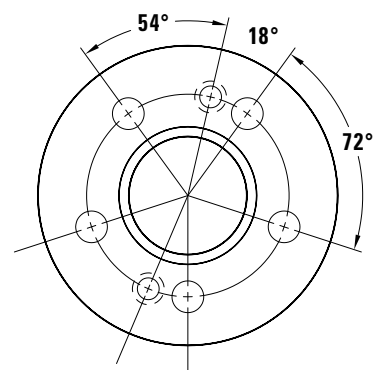

Hints on QD Type Bushings. Installing & Removal

QD® Bushings can be installed in two modes, standard or reverse.

In the conventional mounting, the bushing flange faces inward related to driving shaft and cap screws should be placed first through the sprocket, pulley or roller, on the other side of the bushing and then bolted into the bushing.

The mounting procedure starts with a thorough cleaning of the shaft, the bushing bore, the flange and rest of surface and removing the burrs if any.

The sprocket set, pulley or roller with bush must be assembled first by aligning the drilled holes of the sprocket, pulley or roller with the tapped holes in the flange of the bush. Insert the cap screws on the sprocket, pulley or roller side along with the washers and hand tighten the cap screws.

In the reverse mounting, the process is the other way round, with the bush flange facing outward related to driving shaft. Align the drilled

holes of the bush.

Flange with tapped holes of the sprocket, pulley or roller. Insert the cap screws outside of the assembly and hand tighten them.

Finally slide the assembly into the shaft with the key sitting in the shaft's keyway. Once the assembly is in proper place tighten the cap screws as appropriate according the suggested torque in the table below, leaving a gap between the face of the sprocket, pulley or roller and the flange, starting with half the recommended torque, check the alignment and tight the cap screws up to the full recommended torque without completely closing the gap.

Whenever provided, tighten the set screw at the flange to secure the key.

To remove the assembly, loose the cap screws remove them and screw into tapped holds. Tighten first the furthest from slot and alternatively tight the screws until break the taper grip.

QD Bushing Bolt Torque values

QD TYPE	CAP SCREWS*		TORQUE IN* LBS	CAP SCREWS**		TORQUE N* M
	Size	Qty		Size		
TL-JA	10-24 UNC x 1	3	60	M5 x 0,8 x 22	9,6	
TL-SH	1/4-20 UNC x 1 3/8	3	108	M6 x 1 x 35	11,5	
TL-SDS	1/4-20 UNC x 1 3/8	3	108	M6 x 1 x 35	11,5	
TL-SD	1/4-20 UNC x 1 3/8	3	108	M6 x 1 x 50	11,5	
TL-SK	5/16 -18 UNC x 2	3	180	M8 x 1,25 x 50	20,5	
TL-SF	3/8-16 UNC x 2	3	360	M10 x 1,5 x 50	34	
TL-E	1/2-13 UNC x 2 3/4	3	720	M12 x 1,75 x 70	77	
TL-F	9/16-12 UNC x 3 5/8	3	900	M14 x 2 x 100	100	
TL-J	5/8-11 UNC x 4 1/2	3	1620	M16 x 2 x 120	194,5	
TL-M	3/4-10 UNC x 6 3/4	4	2700	M20 x 2,5 x 180	256	
TL-N	7/8-9 UNC x 8	4	3600	M22 x 2,5	290	
TL-P	1-8 UNC x 9 1/2	4	5400			
TL-W	1 1/8-7 UNC x 11 1/2	4	7200			
TL-S	1 1/4-7 UNC x 15 1/2	5	9000			

* All dimensions in inches.

** All dimensions in mm.

Standard mounting

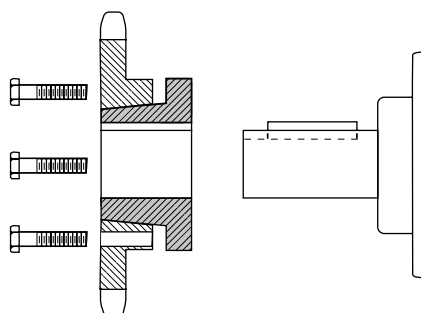

Reverse mounting

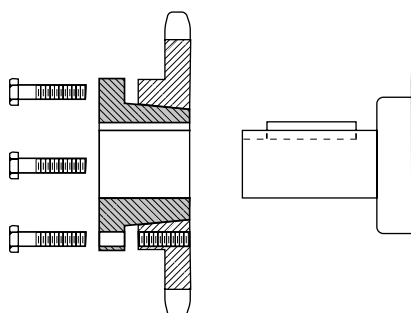

Reverse mounting. Types JA through J are drilled with six holes, three of them drilled and three tapped so that pull-up bolts can be

inserted from either side thus having a wider versatility to adapt to different installations.

ST SPLIT TAPER TYPE BUSHINGS

These type of bushings are characterized by having an external flange, a double key one to the shaft and another to the drive element, double split through the barrel up to the flange, a nominal 3/4" per foot taper i.e. 1° 47' 17.5" (6,25%), conventional and reverse mount capacity. The double split tapered barrel provides bigger adaptability to the shaft size as compared to a bore to size element while the double key and the taper provides a high degree of mechanical locking.

There are available four types, namely the G&H, the P, B, Q & R, the S & U and finally the W & Y and two versions of each according to the bore range.

We offer a wide choice of sizes and as far as materials are concerned, we offer steel and stainless steel versions. The tables ahead display the sizes of the program while other sizes and materials may be available on MTO base.



Type 1 G & H - P, B, Q & R - S & U - W & Y

BUSHING	DIMENSIONS												BORE RANGE	CAP SCREWS		WEIGHT		TORQUE	
	L	U	T	Large End D	Small End D	H	V	W	X	Y	R	S		No.	Size	Kgs	Lbs.	in.lbs	m.N
TL-ST-G-1	1"	1/4"	3/4"	1,172"	1,133"	2"	1 9/16"		5/8"	3/16"	1/8"	3/16"	3/8"-15/16"	2	1/4"x5/8"	0,227	0,50	95	10,94
TL-ST-H-1	1 1/4	1/4	1	1,625	1,570	2 1/2	2		7/8	3/16	1/8	3/16	3/8-1 3/8	2	1/4x3/4	0,363	0,80	95	10,94
TL-ST-P1-1	1 15/16	13/32	1 17/32	1,9375	1,8555	3"	2 7/16	3/8"	1 5/16	7/32	7/32	1/4	1/2-1 7/16	3	5/16x1	0,590	1,30	192	22,12
TL-ST-P2-1	2 15/16	13/32	2 17/32	1,9375	1,7930	3"	2 7/16	3/8	2 5/16	7/32	7/32	1/4	3/4-1 7/16	3	5/16x1	0,680	1,50	192	22,12
TL-ST-P3-1	4 7/16	13/32	4 1/32	1,9375	1,6993	3"	2 1/16	3/8	3 13/16	7/32	7/32	1/4	1 1/8-1 3/8	3	5/16x1	0,907	2,00	192	22,12
TL-ST-B-1	1 15/16	1/2	1 7/16	2,625	2,5567	3 11/16	3 1/8	1/2	1 3/16	7/32	1/4	1/4	1/2-1 5/16	3	5/16x1 1/4	0,816	1,80	192	22,12
TL-ST-Q1-1	2 1/2	17/32	1 31/32	2,875	2,7657	4 1/8	3 3/8	1/2	1 3/4	7/32	7/32	9/32	3/4-2 1/16	3	3/8x1 1/4	1,587	3,50	348	40,09
TL-ST-Q2-1	3 1/2	17/32	2 31/32	2,875	2,7032	4 1/8	3 3/8	1/2	2 3/4	7/32	7/32	9/32	1"-2 1/16	3	3/8x1 1/4	2,041	4,50	348	40,09
TL-ST-Q3-1	5	17/32	4 15/32	2,875	2,6094	4 1/8	3 3/8	1/2	4 1/4	7/32	7/32	9/32	1 3/8-2 1/16	3	3/8x1 1/4	2,494	5,50	348	40,09
TL-ST-R1-1	2 7/8	5/8	2 1/4	4,000	3,8750	5 3/8	4 5/8	3/4	2"	1/4	1/4	9/32	1 1/8-2 13/16	3	3/8x1 3/4	3,401	7,50	348	40,09
TL-ST-R2-1	4 7/8	5/8	4 1/4	4,000	3,7500	5 3/8	4 5/8	3/4	4"	1/4	1/4	9/32	1 3/8-2 13/16	3	3/8x1 3/4	4,989	11,00	348	40,09
TL-ST-S1-1	4 3/8	3/4	3 5/8	4,625	4,4180	6 3/8	5 3/8	3/4	3 5/16	5/16	5/16	3/8	1 11/16-3 3/16	3	1/2x2 1/4	6,122	13,50	840	96,77
TL-ST-S2-1	6 3/4	3/4	6"	4,625	4,2696	6 3/8	5 3/8	3/4	5 11/16	5/16	5/16	3/8	1 7/8-3 3/16	3	1/2x2 1/4	8,617	19,00	840	96,77
TL-ST-U01-1	5 1/4	1 11/16	4 3/16	6,000	5,7656	8 3/8	7"	1 1/4	3 3/4	7/16	7/16	15/32	2 3/8-3 1/16	3	5/8x2 3/4	13,605	30,00	1680	193,54
TL-ST-U02-1	4 15/16	3/4	4 3/16	6,000	5,7656	8 3/8	7"	1 1/4	3 3/4	7/16	7/16	15/32	3 1/4-4 1/4	3	5/8x2 3/4	12,245	27,00	1680	193,54
TL-ST-U1-1	7 1/8	1 11/16	6 1/16	6,000	5,6485	8 3/8	7"	1 1/4	5 5/8	7/16	7/16	15/32	2 3/8-4 1/4	3	5/8x2 3/4	18,141	40,00	1680	193,54
TL-ST-U2-1	10 1/8	1 11/16	9 1/16	6,000	5,4610	8 3/8	7"	1 1/4	8 5/8	7/16	7/16	15/32	2 7/16-4 1/4	3	5/8x2 3/4	22,676	50,00	1680	193,54
TL-ST-W1-1	8 1/4	1 7/16	6 13/16	8,500	8,1016	12 1/2	10"	1 1/4	6 3/8	7/16	7/16	9/16	3 3/8-6 3/16	4	3/4x3	47,166	104,00	3000	345,60
TL-ST-W2-1	11 1/4	1 7/16	9 13/16	8,500	7,9141	12 1/2	10"	1 1/4	9 3/8	7/16	7/16	9/16	3 3/8-6 3/16	4	3/4x3	60,317	133,00	3000	345,60

All measure in inches.

G & H

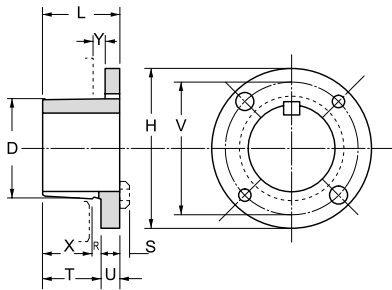

P, B, Q & R

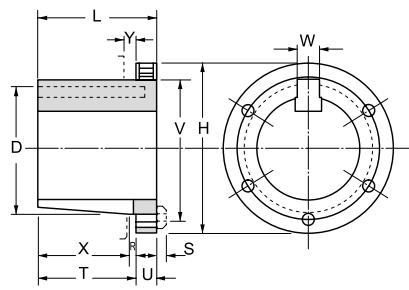

S & U

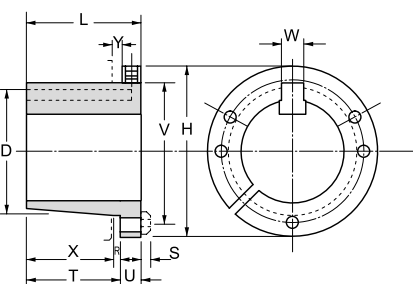

W & Y

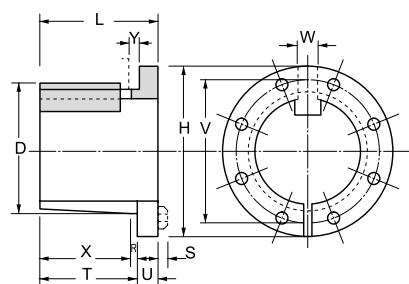

Type 2 G & H - P, B, Q & R - S & U - W & Y

BUSHING	DIMENSIONS												BORE RANGE	CAP SCREWS		WEIGHT		TORQUE	
	L	U	T	Large End D	Small End D	H	V	W	X	Y	R	S		No.	Size	Kgs	Lbs.	in.lbs	m.N
TL-ST-G-2	1"	1/4"	3/4"	1,172"	1,133"	2"	1 9/16"		5/8"	3/16"	1/8"	3/16"	1"	2	1/4"x5/8"	0,227	0,50	95	10,94
TL-ST-H-2	1 1/4	1/4	1	1,625	1,570	2 1/2	2		7/8	3/16	1/8	3/16	1 7/16-1 1/2	2	1/4x3/4	0,363	0,80	95	10,94
TL-ST-P1-2	1 15/16	13/32	1 17/32	1,9375	1,8555	3"	2 7/16	3/8"	1 5/16	7/32	7/32	1/4	1 1/2-1 3/4	3	5/16x1	0,590	1,30	192	22,12
TL-ST-P2-2	2 15/16	13/32	2 17/32	1,9375	1,7930	3"	2 7/16	3/8	2 5/16	7/32	7/32	1/4	1 1/2-1 3/4	3	5/16x1	0,680	1,50	192	22,12
TL-ST-P3-2	4 7/16	13/32	4 1/32	1,9375	1,6993	3"	2 1/16	3/8	3 13/16	7/32	7/32	1/4	1 5/8	3	5/16x1	0,907	2,00	192	22,12
TL-ST-B-2	1 15/16	1/2	1 7/16	2,625	2,5567	3 11/16	3 1/8	1/2	1 3/16	7/32	1/4	1/4	2-2 7/16	3	5/16x1 1/4	0,816	1,80	192	22,12
TL-ST-Q1-2	2 1/2	17/32	1 31/32	2,875	2,7657	4 1/8	3 3/8	1/2	1 3/4	7/32	7/32	9/32	2 1/8-2 11/16	3	3/8x1 1/4	1,587	3,50	348	40,09
TL-ST-Q2-2	3 1/2	17/32	2 31/32	2,875	2,7032	4 1/8	3 3/8	1/2	2 3/4	7/32	7/32	9/32	2 1/8-2 5/8	3	3/8x1 1/4	2,041	4,50	348	40,09
TL-ST-Q3-2	5	17/32	4 15/32	2,875	2,6094	4 1/8	3 3/8	1/2	4 1/4	7/32	7/32	9/32	2 1/8-2 1/2	3	3/8x1 1/4	2,494	5,50	348	40,09
TL-ST-R1-2	2 7/8	5/8	2 1/4	4,000	3,8750	5 3/8	4 5/8	3/4	2"	1/4	1/4	9/32	2 7/8-3 3/4	3	3/8x1 3/4	3,401	7,50	348	40,09
TL-ST-R2-2	4 7/8	5/8	4 1/4	4,000	3,7500	5 3/8	4 5/8	3/4	4"	1/4	1/4	9/32	2 7/8-3 5/8	3	3/8x1 3/4	4,989	11,00	348	40,09
TL-ST-S1-2	4 3/8	3/4	3 5/8	4,625	4,4180	6 3/8	5 3/8	3/4	3 5/16	5/16	5/16	3/8	3 1/4-4 1/4	3	1/2x2 1/4	6,122	13,50	840	96,77
TL-ST-S2-2	6 3/4	3/4	6"	4,625	4,2696	6 3/8	5 3/8	3/4	5 11/16	5/16	5/16	3/8	3 1/4-4 3/16	3	1/2x2 1/4	8,617	19,00	840	96,77
TL-ST-U01-2	5 1/4	1 1/16	4 3/16	6,000	5,7656	8 3/8	7"	1 1/4	3 3/4	7/16	7/16	15/32		3	5/8x2 3/4	13,605	30,00	1680	193,54
TL-ST-U02-2	4 15/16	3/4	4 3/16	6,000	5,7656	8 3/8	7"	1 1/4	3 3/4	7/16	7/16	15/32	4 3/8-5 1/2	3	5/8x2 3/4	12,245	27,00	1680	193,54
TL-ST-U1-2	7 1/8	1 1/16	6 1/16	6,000	5,6485	8 3/8	7"	1 1/4	5 5/8	7/16	7/16	15/32	4 3/8-5 1/2	3	5/8x2 3/4	18,141	40,00	1680	193,54
TL-ST-U2-2	10 1/8	1 1/16	9 1/16	6,000	5,4610	8 3/8	7"	1 1/4	8 5/8	7/16	7/16	15/32	4 3/8-5	3	5/8x2 3/4	22,676	50,00	1680	193,54
TL-ST-W1-2	8 1/4	1 7/16	6 13/16	8,500	8,1016	12 1/2	10"	1 1/4	6 3/8	7/16	7/16	9/16	6 1/4-7 7/16	4	3/4x3	47,166	104,00	3000	345,60
TL-ST-W2-2	11 1/4	1 7/16	9 13/16	8,500	7,9141	12 1/2	10"	1 1/4	9 3/8	7/16	7/16	9/16	6 1/4-7 7/16	4	3/4x3	60,317	133,00	3000	345,60

All dimensions in inches.

G & H

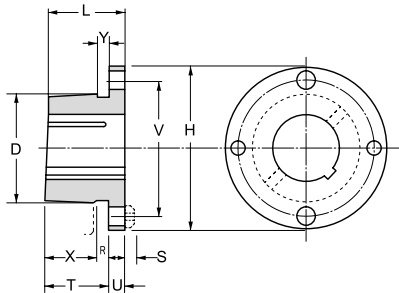

P, B, Q & R

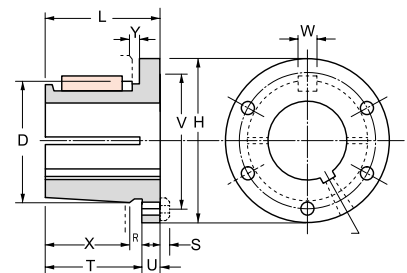

S & U

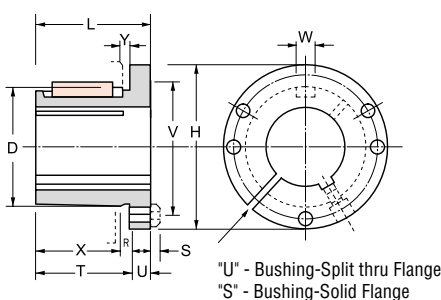

W & Y

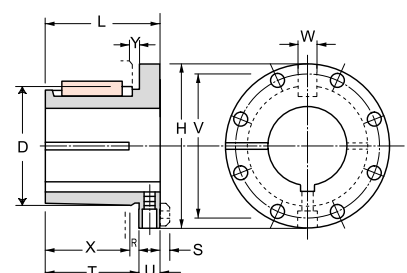

REFERENCE	KEYSEAT
TL-STG.3/8	
TL-STG.7/16	
TL-STG.1/2	1/8x1/16
TL-STG.9/16	1/8x1/16
TL-STG.5/8	3/16x3/32
TL-STG.11/16	3/16x3/32
TL-STG.3/4	3/16x3/32
TL-STG.13/16	3/16x3/32
TL-STG.7/8	3/16x3/32
TL-STG.15/16	1/4x1/8
TL-STG.1	1/4x1/8
TL-ST-STH.3/8	
TL-ST-STH.7/16	
TL-ST-STH.1/2	1/8x1/16
TL-ST-STH.9/16	1/8x1/16
TL-ST-STH.5/8	3/16x3/32
TL-ST-STH.11/16	3/16x3/32
TL-ST-STH.3/4	3/16x3/32
TL-ST-STH.13/16	3/16x3/32
TL-ST-STH.7/8	3/16x3/32
TL-ST-STH.15/16	1/4x1/8
TL-ST-STH.1	1/4x1/8
TL-ST-STH.1-1/16	1/4x1/8
TL-ST-STH.1-1/8	1/4x1/8
TL-ST-STH.13/16	1/4x1/8
TL-ST-STH.1-1/4	1/4x1/8
TL-ST-STH.1-5/16	5/16x5/32
*TL-ST-STH.1-3/8	5/16x5/32
*TL-ST-STH.1-3/8	3/8x3/16
TL-ST-STH.1-7/16	3/8x3/16
TL-ST-STH.1-1/2	3/8x3/16
TL-STP1.1/2	1/8x1/16
TL-STP1.9/16	1/8x1/16
TL-STP1.5/8	3/16x3/32
TL-STP1.11/16	3/16x3/32
TL-STP1.3/4	3/16x3/32
TL-STP1.13/16	3/16x3/32
TL-STP1.7/8	3/16x3/32
TL-STP1.15/16	1/4x1/8
TL-STP1.1	1/4x1/8
TL-STP1.1-1/16	1/4x1/8
TL-STP1.1-1/8	1/4x1/8
TL-STP1.1-3/16	1/4x1/8
TL-STP1.1-1/4	1/4x1/8
TL-STP1.1-5/16	5/16x5/32
*TL-STP1.1-3/8	5/16x5/32
*TL-STP1.1-3/8	3/8x3/16
TL-STP1.1-7/16	3/8x3/16
TL-STP1.1-1/2	3/8x3/16
TL-STP1.1-9/16	3/8x3/16
TL-STP1.1-5/8	3/8x3/16
TL-STP1.1-11/16	3/8x3/16
TL-STP1.1-3/4	3/8x3/16
TL-STP2.3/4	3/16x3/32
TL-STP2.13/16	3/16x3/32
TL-STP2.7/8	3/16x3/32
TL-STP2.15/16	1/4x1/8
TL-STP2.1	1/4x1/8
TL-STP2.1-1/16	1/4x1/8
TL-STP2.1-1/8	1/4x1/8
TL-STP2.1-3/16	1/4x1/8
TL-STP2.1-1/4	1/4x1/8
TL-STP2.1-5/16	5/16x5/32
*TL-STP2.1-3/8	5/16x5/32
*TL-STP2.1-3/8	3/8x3/16
TL-STP2.1-7/16	3/8x3/16
TL-STP2.1-1/2	3/8x3/16
TL-STP2.1-9/16	3/8x3/16
TL-STP2.1-5/8	3/8x3/16
TL-STP2.1-11/16	3/8x3/16
TL-STP2.1-3/4	3/8x3/16
TL-STP3.1-1/8	1/4x1/8
TL-STP3.1-3/16	1/4x1/8
TL-STP3.1-1/4	
TL-STP3.1-5/16	
*TL-STP3.1-3/8	5/16x5/32
*TL-STP3.1-3/8	
TL-STP3.1-7/16	
TL-STP3.1-1/2	
TL-STP3.1-9/16	
TL-STP3.1-5/8	3/8x3/16
TL-STQ1.3/8	
TL-STQ1.7/16	
TL-STQ1.1/2	
TL-STQ1.9/16	
TL-STQ1.5/8	
TL-STQ1.11/16	
TL-STQ1.3/4	3/16x3/32
TL-STQ1.13/16	3/16x3/32
TL-STQ1.7/8	3/16x3/32
TL-STQ1.15/16	1/4x1/8
TL-STQ1.1	1/4x1/8
TL-STQ1.1-1/16	1/4x1/8
TL-STQ1.1-1/8	1/4x1/8
TL-STQ1.1-3/16	1/4x1/8
TL-STQ1.1-1/4	1/4x1/8
TL-STQ1.1-5/16	5/16x5/32
TL-STQ1.1-3/8	5/16x5/32
TL-STQ1.1-3/8	3/8x3/16
TL-STQ1.1-7/16	3/8x3/16
TL-STQ1.1-1/2	3/8x3/16
TL-STQ1.1-9/16	3/8x3/16
TL-STQ1.1-5/8	3/8x3/16
TL-STQ1.1-11/16	3/8x3/16
TL-STQ1.1-3/4	3/8x3/16
TL-STQ1.1-13/16	1/4x1/8
TL-STQ1.1-7/8	1/2x1/4
TL-STQ1.1-15/16	1/2x1/4
TL-STQ1.2	1/4x1/4
TL-STQ1.2-1/16	1/2x1/4
TL-STQ1.2-1/8	1/2x1/4
TL-STQ1.2-3/16	1/2x1/4
TL-STQ1.2-1/4	1/2x1/4
TL-STQ1.2-5/16	5/8x5/16
TL-STQ1.2-3/8	5/8x5/16
TL-STQ1.2-7/16	5/8x5/16
TL-STQ1.2-1/2	5/8x5/16
TL-STQ1.2-9/16	3/8x5/16
TL-STQ1.2-5/8	5/8x5/16
TL-STQ1.2-11/16	5/8x5/16

REFERENCE	KEYSEAT
TL-STQ2.1	1/4x1/8
TL-STQ2.1-1/16	1/4x1/8
TL-STQ2.1-1/8	1/4x1/8
TL-STQ2.1-3/16	1/4x1/8
TL-STQ2.1-1/4	1/4x1/8
TL-STQ2.1-5/16	5/16x5/32
*TL-STQ2.1-3/8	5/16x5/32
*TL-STQ2.1-3/8	3/8x3/16
TL-STQ2.1-7/16	3/8x3/16
TL-STQ2.1-1/2	3/8x3/16
TL-STQ2.1-9/16	3/8x3/16
TL-STQ2.1-5/8	3/8x3/16
TL-STQ2.1-11/16	3/8x3/16
TL-STQ2.1-3/4	3/8x3/16
TL-STQ2.1-13/16	1/2x1/4
TL-STQ2.1-7/8	1/2x1/4
TL-STQ2.1-15/16	1/2x1/4
TL-STQ2.2	1/4x1/4
TL-STQ2.2-1/16	1/2x1/4
TL-STQ2.2-1/8	1/2x1/4
TL-STQ2.2-3/16	1/2x1/4
TL-STQ2.2-1/4	1/2x1/4
TL-STQ2.2-5/16	5/8x5/16
TL-STQ2.2-3/8	5/8x5/16
TL-STQ2.2-7/16	5/8x5/16
TL-STQ2.2-1/2	5/8x5/16
TL-STQ2.2-9/16	3/8x5/16
TL-STQ2.2-5/8	5/8x5/16
TL-STQ3.3/8	
TL-STQ3.7/16	
TL-STQ3.1/2	
TL-STQ3.9/16	
TL-STQ3.5/8	
TL-STQ3.11/16	
TL-STQ3.3/4	
TL-STQ3.13/16	
TL-STQ3.7/8	
TL-STQ3.15/16	
TL-STQ3.1	
TL-STQ3.1-1/16	
TL-STQ3.1-1/8	
TL-STQ3.1-3/16	
TL-STQ3.1-1/4	
TL-STQ3.1-5/16	5/16x5/32
TL-STQ3.1-3/8	3/8x3/16
TL-STQ3.1-1/2	3/8x3/16
TL-STQ3.1-9/16	3/8x3/16
TL-STQ3.1-5/8	3/8x3/16
TL-STQ3.1-11/16	3/8x3/16
TL-STQ3.1-3/4	3/8x3/16
TL-STQ3.1-7/16	3/8x3/16
TL-STQ3.1-1/2	3/8x3/16
TL-STQ3.1-9/16	3/8x3/16
TL-STQ3.1-5/8	3/8x3/16
TL-STQ3.1-11/16	3/8x3/16
TL-STQ3.1-3/4	3/8x3/16
TL-STQ3.1-13/16	1/2x1/4
TL-STQ3.1-7/8	1/2x1/4
TL-STQ3.1-15/16	1/2x1/4
TL-STQ3.2	1/4x1/4
TL-STQ3.2-1/16	1/2x1/4
TL-STQ3.2-1/8	1/2x1/4
TL-STQ3.2-3/16	1/2x1/4
TL-STQ3.2-1/4	1/2x1/4
TL-STQ3.2-5/16	5/8x5/16
TL-STQ3.2-3/8	5/8x5/16
TL-STQ3.2-7/16	5/8x5/16
TL-STQ3.2-1/2	5/8x5/16
TL-STQ3.2-9/16	3/8x5/16
TL-STQ3.2-5/8	5/8x5/16
TL-STQ3.2-11/16	5/8x5/16

REFERENCE	KEYSEAT
TL-STQ3.2-3/8	5/8x5/16
TL-STQ3.2-7/16	5/8x5/16
TL-STQ3.2-1/2	
TL-STR1.3/8	
TL-STR1.7/16	
TL-STR1.1/2	
TL-STR1.9/16	
TL-STR1.5/8	
TL-STR1.11/16	
TL-STR1.3/4	
TL-STR1.13/16	
TL-STR1.7/8	
TL-STR1.15/16	
TL-STR1.1	
TL-STR1.1-1/16	
TL-STR1.1-1/8	
TL-STR1.1-3/16	1/4x1/8
TL-STR1.1-1/4	1/4x1/8
TL-STR1.1-5/16	1/4x1/8
*TL-STR1.1-3/8	5/16x5/32
*TL-STR1.1-3/8	5/16x5/32
TL-STR1.1-7/16	3/8x3/16
TL-STR1.1-1/2	3/8x3/16
TL-STR1.1-9/16	3/8x3/16
TL-STR1.1-5/8	3/8x3/16
TL-STR1.1-11/16	3/8x3/16
TL-STR1.1-3/4	3/8x3/16
TL-STR1.1-13/16	3/8x3/16
TL-STR1.1-7/8	1/2x1/4
TL-STR1.1-15/16	1/2x1/4
TL-STR1.2	1/2x1/4
TL-STR1.2-1/16	1/4x1/4
TL-STR1.2-1/8	1/2x1/4
TL-STR1.2-3/16	1/2x1/4
TL-STR1.2-1/4	1/2x1/4
TL-STR1.2-5/16	1/2x1/4
TL-STR1.2-3/8	5/8x5/16
TL-STR1.2-7/16	5/8x5/16
TL-STR1.2-1/2	5/8x5/16
TL-STR1.2-9/16	5/8x5/16
TL-STR1.2-5/8	3/8x5/16
TL-STR1.2-11/16	5/8x5/16
TL-STR1.2-3/4	5/8x5/16
TL-STR1.2-13/16	5/8x5/16
TL-STR1.2-7/8	3/4x3/8
TL-STR1.2-15/16	3/4x3/8
TL-STR1.3	3/4x3/8
TL-STR1.3-1/16	3/4x3/8
TL-STR1.3-1/8	
TL-STR1.3-3/16	3/4x3/8
TL-STR1.3-1/4	3/4x3/8
TL-STR1.3-5/16	3/4x3/8
TL-STR1.3-3/8	
TL-STR1.3-7/16	7/8x7/16
TL-STR1.3-1/2	7/8x7/16
TL-STR1.3-9/16	7/8x7/16
TL-STR1.3-5/8	
TL-STR1.3-11/16	7/8x7/16
TL-STR1.3-3/4	7/8x7/16

* 1 3/8 Bores may use 5/16 x 5/32 and 3/8 x 3/16 Keyways. By default the former is delivered.



ST Split Taper Type Weld-On Bushings

There are three types available, the H hubs, the P, Q, R, S, Y, U hubs and the W hubs.

REFERENCE*	BUSH TYPE	D	L	P	L1	B	K	BOLT CIRCLE	w	α°	THREAD HOLES		WEIGHT	
											#	Size	lbs	Kgs
TL-ST-HH1	H	2,50	0,88	2,375	0,174	1,621		2,00			2	1/4 UNC-20	0,60	0,27
TL-ST-HCH1	H	2,50	0,88	2,375	0,625	1,621		2,00			2	1/4 UNC-20	0,70	0,32
TL-ST-HP1	P1	3,00	1,31	2,875	0,292	1,938	1,094	2,44	0,38	60	3	5/16 UNC-18	1,40	0,64
TL-ST-HCP1	P1	3,00	1,31	2,875	1,000	1,938	1,094	2,44	0,38	60	3	5/16 UNC-18	1,10	0,50
TL-ST-HP2	P2	3,00	2,31	2,875	1,100	1,938	1,094	2,44	0,38	60	3	5/16 UNC-18	2,50	1,13
TL-ST-HQ1	Q1	4,50	1,75	4,375	0,709	2,875	1,562	3,38	0,50	60	3	3/8 UNC-16	4,40	2,00
TL-ST-HCQ1	Q1	4,50	1,75	4,375	1,250	2,875	1,562	3,38	0,50	60	3	3/8 UNC-16	4,40	2,00
TL-ST-HQ2	Q2	4,50	2,75	4,375	1,606	2,875	1,562	3,38	0,50	60	3	3/8 UNC-16	6,90	3,13
TL-ST-HR1	R1	5,75	2,00	5,625	0,709	4,000	2,188	4,63	0,75	60	3	3/8 UNC-16	7,30	3,31
TL-ST-HR2	R2	5,75	4,00	5,625	1,606	4,000	2,188	4,63	0,75	60	3	3/8 UNC-16	15,40	6,99
TL-ST-HS1	S1	6,75	3,31	6,500	0,946	4,625	2,562	5,38	0,75	60	3	1/2 UNC-13	17,30	7,85
TL-ST-HS2	S2	6,75	5,69	6,500	2,963	4,625	2,562	5,38	0,75	60	3	1/2 UNC-13	30,40	13,79
TL-ST-HUO	UO	8,50	3,75	8,250	2,000	6,000	3,250	7,00	1,25	60	3	5/8 UNC-11	32,00	14,52
TL-ST-HU1	U1	8,50	5,62	8,250	2,963	6,000	3,250	7,00	1,25	60	3	5/8 UNC-11	44,60	20,23
TL-ST-HU2	U2	8,50	8,62	8,250	6,016	6,000	3,250	7,00	1,25	60	3	5/8 UNC-11	69,00	31,30
TL-ST-HW1	W1	12,50	6,38	12,250	2,963	8,500	4,562	10,00	1,25	22 1/2	4	3/4 UNC-10	130,00	58,97

* All measures in inches.

H HUBS

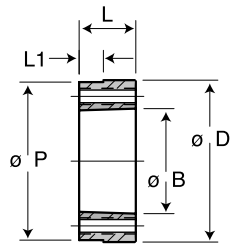
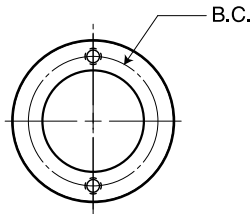

ALL TAPERS .75" PER FT. ON DIAMETER



P, Q, R, S, Y, U HUBS

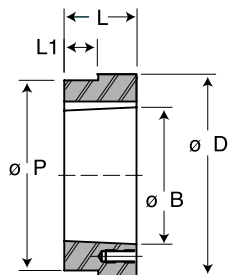
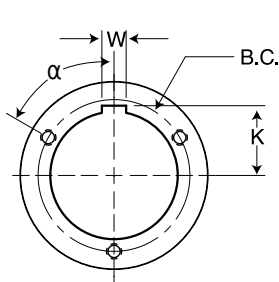

W HUBS

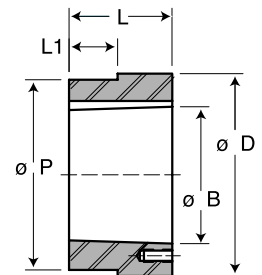
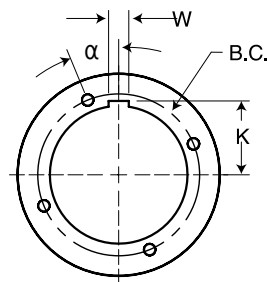

Used for insertion and welding to produce B type sprockets, pulleys and other applications without hub protrusion. Manufactured to accept Split Taper Bushings of the four types, namely the G & H, the P,

B, Q & R, the S & U and finally the W & Y and two versions of each according to the bore range.

Hints on ST Type Bushings. Installing & Removal

The mounting and removal procedure of ST Type of Taper Bushings is very similar to that of the QD type of Taper Bushings. The main distinguishing features are that they are split through the barrel while the QD is split through the flange and that they are keyed in the shaft and in the bushing conferring a powerful grip. The taper.

They can be mounted in Standard with Flange Inboard position or Reverse with Flange Outward as seen in the illustrations ahead, where it can be appreciated that the installation holes are not threaded while the removal holes are threaded for a soft extraction.

Installation:

- Clean the shaft, the bushing, the barrel and the bore to make them free of burrs, paints and lubricants if any.
- Insert the bushing in the pulley, sprocket or gear
- Insert the cap-screws loose in the corresponding holes.
- Slide the pulley, sprocket or gear to their position in the shaft with the key in.
- Align the pulley, sprocket or gear and tighten the cap screws alternatively up to the recommended torque in the table ahead, leaving a gap between the bushing and the transmission element.

For removal, proceed to:

- Loose and take the cap screws off.
- Insert the cap screws in threaded removal holes.
- Tighten the removal cap screws until the element is released from the bushing.

IMPORTANT: Do not use any type of lubricant on the taper cone, the shaft, the pulley or sprocket and nor on the cap screws.

Always take the power off and lock it out before installation or removal. Pay the utmost attention to the safety procedures also when installing, removing or maintaining.

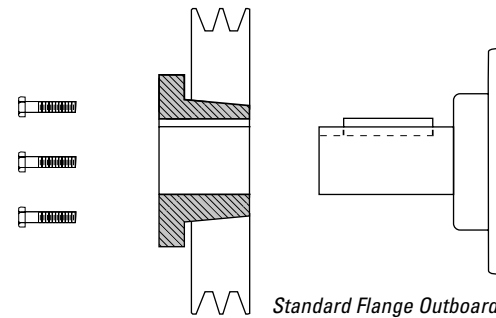
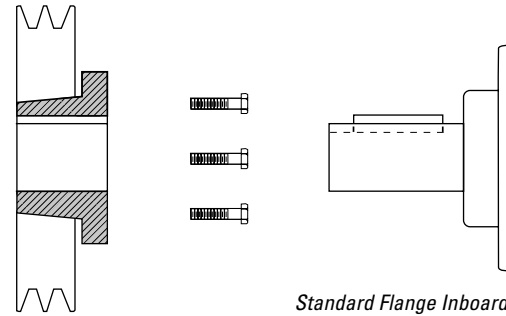
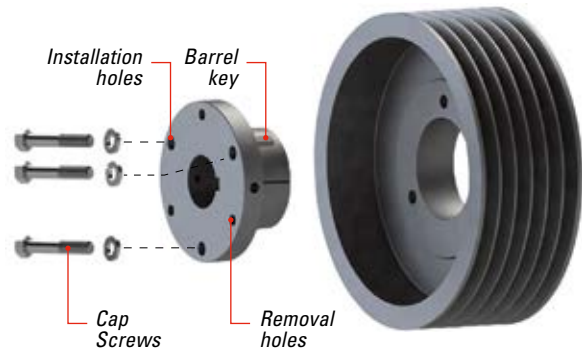

XT TYPE BUSHINGS & XT WELD-ON HUBS

Used mainly for conveyor pulley applications. The higher taper degree of 2" per foot and Split through the barrel and flange, makes an easy mounting and removal. The insertion of XT Type Bushings into XT Weld-On Hubs produce a B type Pulley, Sprocket and others without protrusion. The bolts are equally spaced exerting a uniform

pressure while the high taper degree facilitates a self-seating reducing the stress. We offer a wide choice of bores and as far as materials are concerned, we offer steel and stainless steel options. The tables ahead display the Standard sizes, although other sizes and materials are available under MTO basis

XT STYLE BUSHING

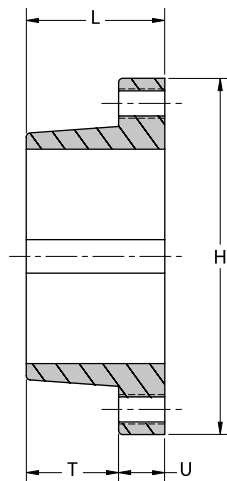
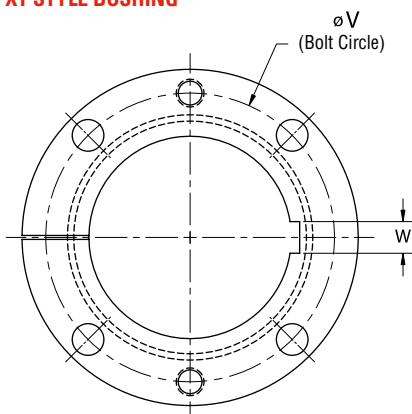

BUSHING*	L	U	T	H	V	MAXIMUM BORE	CAP SCREWS		WEIGHT	
							#	Size	lbs	Kgs
TL-XTB15	1 1/8	3/8	3/4	2 7/8	2 7/16	1 1/2	90,00	1/4 x 1-20 UNC	0,70	0,32
TL-XTB20	1 13/32	15/32	15/16	3 3/4	3 3/16	2	200,00	5/16 x 1 1/4-18 UNC	1,50	0,68
TL-XTB25	1 7/8	5/8	1 1/4	4 7/16	3 3/4	2 7/16	350,00	3/8 x 1 1/4-16 UNC	2,60	1,18
TL-XTB30	2 1/16	11/16	1 3/8	5 5/16	4 9/16	2 15/16	550,00	7/16 x 1 1/2-14 UNC	4,20	1,91
TL-XTB35	2 15/32	25/32	1 11/16	6 5/16	5 7/16	3 7/16	840,00	1/2 x 1 3/4-13 UNC	7,40	3,36
TL-XTB40	2 13/16	7/8	1 15/16	7 1/8	6 1/8	3 15/16	1200,00	9/16 x 2-12 UNC	10,50	4,76
TL-XTB45	3 5/16	15/16	2 3/8	8	6 7/8	4 7/16	1680,00	5/8 x 2 1/4-11 UNC	14,80	6,72
TL-XTB50	3 3/4	1	2 3/4	10 1/8	8 5/16	1 1/4	3000,00	3/4 x 2 1/2-10 UNC	27,80	12,61
TL-XTB60	4 1/8	1 1/8	3	11 15/16	9 7/8	6	4800,00	7/8 x 2 1/2-9 UNC	42,80	19,42
TL-XTB70	4 11/16	1 5/16	3 3/8	13 15/16	11 9/16	7	7200,00	1 x 3-8 UNC	66,30	30,08
TL-XTB80	5 1/8	1 3/8	3 3/4	15 5/8	12 7/8	8	9000,00	1 1/8 x 3 1/2-7 UNC	85,70	38,88
TL-XTB100	6 3/16	1 9/16	4 5/8	17 15/16	15 9/16	10	9000,00	1 1/8 x 3 1/2-7 UNC	146,00	66,24
TL-XTB120	7 1/16	1 3/4	5 15/16	20 5/8	18 3/16	12	9000,00	1 1/8 x 3 1/2-7 UNC	216,00	98,00

* All measures in inches.

XT HUB*	BUSHING	OUTER DIA OD	OUTER DIA SOCKET C	A	X	BOLT CIRCLE V	# BOLTS	TAPPED HOLES	TORQUE		WEIGHT	
									in.lb	m.N	lbs	Kgs
TL-XTH15	TL-XTB15	3,190	2 7/8	7/16	5/8	2 7/16	4	90,00	90,00	10,37	0,70	0,318
TL-XTH20	TL-XTB20	4,065	3 3/4	9/16	1 13/16	3 3/16	4	200,00	200,00	23,04	1,50	0,681
TL-XTH25	TL-XTB25	4,690	4 1/2	13/16	1 1/8	3 3/4	4	350,00	350,00	40,32	2,60	1,180
TL-XTH30	TL-XTB30	5,940	5 3/4	7/8	1 1/4	4 9/16	4	550,00	550,00	63,36	4,10	1,860
TL-XTH35	TL-XTB35	6,565	6 1/2	1 1/16	1 1/2	5 7/16	4	840,00	840,00	96,77	6,60	2,995
TL-XTH40	TL-XTB40	7,562	7 1/2	1 1/4	1 3/4	6 1/8	4	1200,00	1200,00	138,24	10,70	4,855
TL-XTH45	TL-XTB45	8,315	8	1 1/2	2 1/8	6 7/8	4	1680,00	1680,00	193,54	15,40	6,987
TL-XTH50	TL-XTB50	9,940	9 7/8	1 3/4	2 1/2	8 5/16	4	3000,00	3000,00	345,60	24,90	11,298
TL-XTH60	TL-XTB60	11,690	11 1/2	1 15/16	2 3/4	9 7/8	4	4800,00	4800,00	552,96	36,40	16,515
TL-XTH70	TL-XTB70	13,627	13 1/2	2 3/16	3 1/8	11 9/16	4	7200,00	7200,00	829,44	75,60	34,301
TL-XTH80	TL-XTB80	14,940	14 3/4	2 7/16	3 7/16	12 7/8	4	9000,00	9000,00	1036,80	57,70	26,179
TL-XTH100	TL-XTB100	17,940	17 1/2	3	4 1/8	15 9/16	6	9000,00	9000,00	1036,80	122,00	55,353
TL-XTH120	TL-XTB120	20,940	20 1/2	3 1/2	4 13/16	18 3/16	8	9000,00	9000,00	1036,80	189,00	85,752

* All dimensions in inch unless otherwise indicated.

BUSHING*	BORE SIZE
TL-XTB15	5/8 - 3/4 - 7/8 - 1 - 1 1/8 - 1 1/4 - 1 7/16 - 1 1/2
TL-XTB20	3/4 - 1 - 1 3/16 - 1 1/4 - 1 7/16 - 1 1/2 - 1 11/16 - 1 15/16 - 2
TL-XTB25	1 - 3/16 - 1 1/4 - 1 7/8 - 1 1/2 - 1 11/16 - 1 15/16 - 2 - 2 3/16 - 2 7/16
TL-XTB30	1 7/16 - 1 1/2 - 1 15/16 - 2 3/16 - 2 7/16 - 2 11/16 - 2 15/16
TL-XTB35	1 15/16 - 2 3/16 - 2 7/16 - 2 11/16 - 2 15/16 - 3 7/16
TL-XTB40	2 7/16 - 2 15/16 - 3 7/16 - 3 15/16
TL-XTB45	3 7/16 - 3 15/16 - 4 7/16
TL-XTB50	3 15/16 - 4 7/16 - 4 15/16
TL-XTB60	5 7/16 - 5 1/2 - 5 15/16 - 6
TL-XTB70	6 7/16 - 6 1/2 - 6 15/16 - 7
TL-XTB80	7 1/2 - 7 15/16 - 8
TL-XTB100	8 1/2 - 9 - 9 7/16 - 9 1/2 - 10
TL-XTB120	10 1/2 - 11 - 11 1/2 - 12

* All measures in inches.

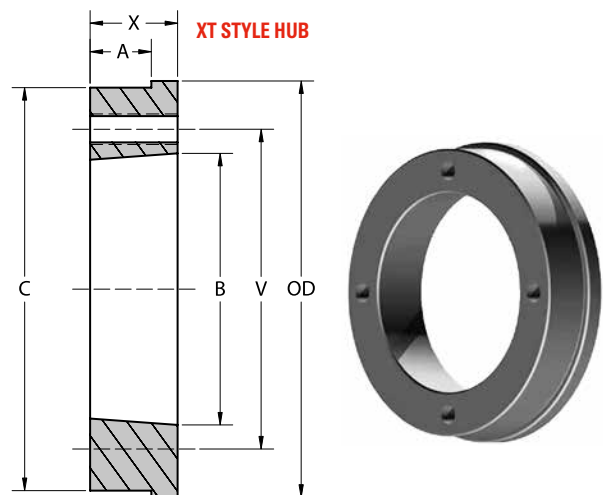

BUSHING & MATING HUB SELECTION

To select a Bushing and its mating Hub, there are some considerations to be taken into account given the different designs available.

The grip to the shaft, the stress to the disc, the bending moment to shaft and the ease to mount and remove are amongst the most important.

TAPERLOCK TYPE

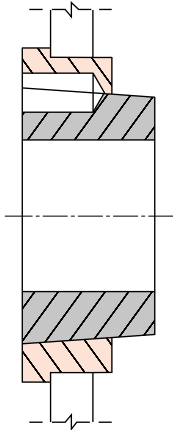

QD TYPE

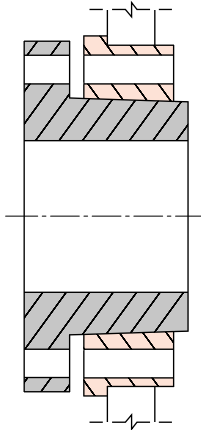

ST TYPE

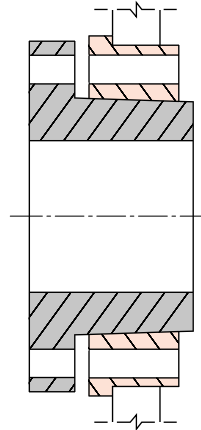

XT TYPE

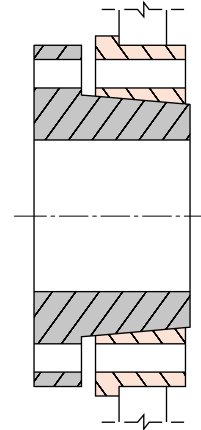

Taper Lock Type Bushing

Its design present 8° taper angle, 1 11/16" per foot or 14,06% gradient. Has a flangeless design permitting a flush-mounting, with no protruding and eliminates wobble. Fixed with half threaded screws. It has the lowest capacity to grip the shaft.

QD Type Bushing

With a design of 3/4" taper per foot, 1° 47' 17.5" angle or 6,25% gradient, split through the barrel and flange has the ability to be mounted from both sides of the hub, giving more mounting versatility. The shallow taper contributes to the stresses or eventually the deflection of the disc.

ST Type Bushing

The taper angle, is the same than the QD Type Bushing, that is, 3/4" taper per foot, 1°47'17.5" angle or 6,25% gradient. The double split through the barrel improves the clamping to the shaft and the external key provides a greater torque carrying capacity and helps the mounting in blind installation.

XT Type Bushing

Designed with 2" taper per foot, 9°27'39" or 8,33% gradient mainly for conveyor pulleys. The high gradient decreases the stress to the disc when mounted, as well as its deflection. The bolts used are equally spaced distributing the pressure evenly around the shaft. The high taper makes the removal to be easy.

BOLT-ON HUBS

Taper Bolt-on Hubs are designed to be used with taper bushings. They are a suitable alternative to Weld-on Hubs. They provide a convenient and easy mounting for fans, impellers and a variety of

devices firmly mounted on shafts. Made out of cast iron or steel and phosphate coated for a higher corrosion resistance.

Types TL-SM & TL-BF

HUB REFERENCE	BUSHING	A	B	C	D	E	J
TL-BO-SM12	1210	180	90	135	25	6,5	6 x 7,5
TL-BO-SM16-1	1610	200	110	150	25	7,5	6 x 7,5
TL-BO-SM16-2	1615	200	110	150	38	7,5	6 x 7,5
TL-BO-SM20	2012	270	140	190	32	8,5	6 x 9,5
TL-BO-SM25	2517	340	170	240	45	9,5	8 x 11,5
TL-BO-SM30-1	3020	430	220	300	51	13,5	8 x 13,5
TL-BO-SM30-2	3020	485	250	340	52	13,5	8 x 13,5

* All measures in mm. Available in inches.

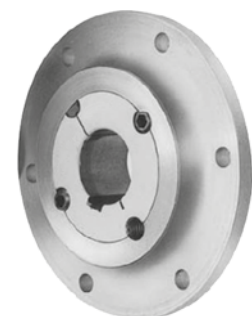

HUB REFERENCE	BUSHING	A	B	C	D	E	G	H	J
TL-BO-BF12	1210	120	80	100	25	5,5	75	10	6 x 7,5
TL-BO-BF16	1610	130	90	110	25	6,5	85	10	6 x 7,5
TL-BO-BF20	2012	145	100	125	32	8,5	95	13	6 x 7,5
TL-BO-BF25	2517	185	130	155	45	11,5	119	20	8 x 11,5
TL-BO-BF30	3020	220	165	190	51	11,5	147	20	8 x 13,5

* All measures in mm. Available in inches.

TYPE TL-SM

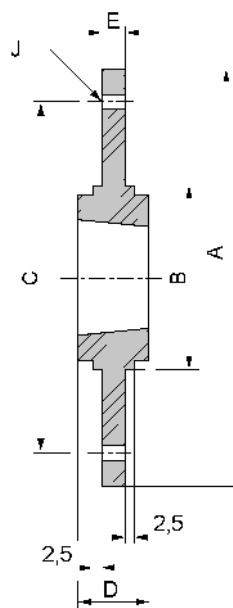

TYPE TL-BF

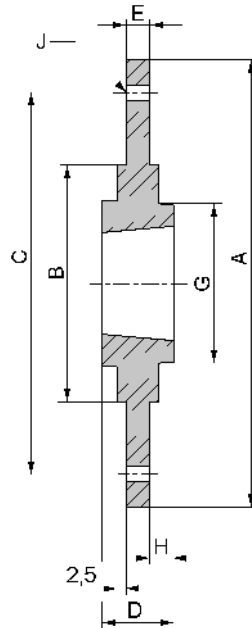

GUIDE TO ORDER

Applied to all products of this Taper Bushings Chapter combining the Product, the Model, the Size, the Material and finally the Treatment, the Plating or Coating if any.

As far as Materials are concerned, all Taper Bushings are made out of Steel Bar Stock, Ductile Casting and Stainless Steel. Any other material or configuration the Customer may need it may be available under MTO with previous consultation with our technical department.

Products: Taper Bushings and Mating Hubs. Bolt-On Hubs

- Taper Lock Type Bushing. Identified by TB and the number
- Taper Lock Type Bushing Reborable. Identified by RTB
- Weld-On Taper Lock type Hub. Identified by TB and S or W for Imperial and WM for Metric
- Quick Detach QD Type Bushing, Identified by JA through S
- Weld-On QD Type Hub. Identified by QD and A or SA
- ST Type Bushing. Identified by ST and G through Y
- Weld-On ST Type Hub. Identified by ST and H, P-Q-R-S-Y-U or W
- XT Type Bushing. Identified by XTB
- Weld-On XT Type Hub. Identified by H
- Bolt-On Hub. Identified by BO and SM or SF

Materials:

Steel (No identification), C (Casting), SS (Stainless Steel)

Platings / Coatings:

BO (Black Oxide), PH (Phosfating), EC (E Coating)

TL -

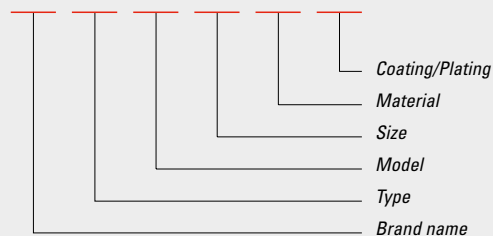

Examples:

TL-TB 1610 5/8 -BO

Taper Bush 1610 5/8" Steel Black Oxide

TL-QD SD 38 -PH

Taper Bush QD SD 38 mm Steel Phosfated

TL-BO 2012 BF-BO

Bolt-On Hub 2012 BF Steel Black Oxide