

# Couplings



# BASICS ON COUPLINGS

Mechanical couplings are designed to connect rotating shafts in a way that they have to be capable to transmit torque, angular speed and at the same time accommodate for misalignments and address vibration, all in all improving the dynamics of the system.

Basically, the mechanical couplings may be grouped in two types, the rigid and the flexible.

The rigid couplings connect firmly the two shafts together without any capability to handle the misalignment. These types are very simple and cost-effective but can only be used in applications where misalignment is of no concern.

The flexible couplings have a flexing element which is devised to absorb the misalignments. There are different types which can be grouped in, Elastomeric, Shear loaded, Metallic flexible, Lubricated, Non lubricated.

Misalignment between the shafts is present from the start at a different degree and develops due to wear of the bearings supporting the shafts, vibration and deflection of the shafts. These effects combined make the wear on the shafts, bearings and the coupling.

Three misalignment forms are recognized to be present between shafts, Axial, Radial or Parallel and Angular.

Axial misalignment or in-out movement is often associated with thermal shaft growth and floating rotors. Thermal growth is the result of high temperature in rotating equipment causing an unconfined growth along the length of its shaft.

Radial or Parallel misalignment occurs when the driving and driven shafts are parallel but with some offset between their axial centers. Accommodating such offset requires either a full-flex coupling, with

two flex planes, or two single-flex couplings in series. In either case, the greater the axial distance between the two flex planes, the greater the coupling's parallel or radial capability. Typical full-flex couplings include gear, grid and dual-element disk or diaphragm types.

Although the elastomeric type has only one flex-plane, the elastomer can distort enough in some cases to provide significant parallel offset capability if it has sufficient resilience. Elastomeric couplings can also be made as spacer or floating shaft types to a limited extent.

Angular misalignment occurs when the axial centers of driving and driven shafts intersect. Flex-rigid or half couplings provide only for angular misalignment because there is only one flex plane. Single-element disk or diaphragm couplings provide for angular misalignment only. Single element couplings are used on three-bearing systems and on one end of floating shaft systems.

Another well-known source of axial movement is the electric motor rotor that seeks its magnetic center. The coupling must either accommodate axial movement or contain it by transferring the thrust to the bearing system of the rotor. Those that contain it are known limited-end float couplings. Sometimes axial thrust is deliberately transferred to another machine through the coupling. Limited-end float may or may not be used in such a case.

Gear couplings exhibit the best capability to handle axial misalignment because the hub teeth are free to slide axially within the sleeve while enmeshed.

Other types of couplings, such as diaphragm couplings can flex or stretch to allow some axial displacement. Disk couplings can also do this, but to a lesser degree than the diaphragm coupling. In both the disk and diaphragm coupling, axial movement is met with resistance that increases as the displacement increases.

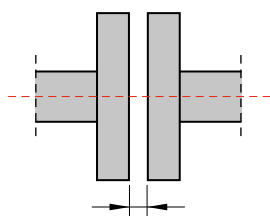

*Axial misalignment*

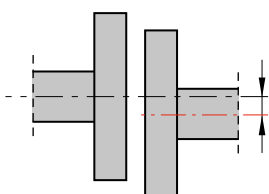

*Radial misalignment*

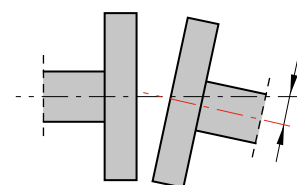

*Angular misalignment*

The combined forms of misalignments compound and affect to the coupling and to the equipment, thus an adequate selection of the coupling will prevent premature wear and failure of the coupling and will protect the equipment.

The main factors to be taken into account include:

- The torque to be transmitted
- The tolerance to misalignment
- The maintenance
- The ease of installation and removal
- The positive shaft engagement
- The service life
- The purchase cost

# STANDARDS

The standards that follow are related either entirely or partially with the Couplings, which we mention for the sake of reference.

**ISO 14691:** Petroleum, petrochemical and natural gas industries. Flexible couplings for mechanical power transmission – General purpose applications.

Applicable to couplings designed to accommodate parallel (or lateral) offset, angular misalignment and axial displacement of the shafts without imposing excessive mechanical loading on the coupled machines. Couplings covered by ISO 14691:2008 include gear (and other mechanical contact types), metallic flexible-element and various elastomeric types. Such couplings can be of all metal construction or can include components of non-metallic materials, such as composites.

**DIN 740 1 & 2:** Power transmission engineering; flexible shaft couplings, parameters and design principles.

Flexible shaft couplings as specified in this standard are used in the field of power transmissions engineering and it may be used for rigid shaft couplings as well. The standards comprises the technical requirements for design and manufacture of flexible shaft couplings.

**AGMA 922 (American Gear Manufacturers Association):** This document lists and classify the character of the load and suggest the service factors.

**ANSI/AGMA 9003-B08:** This standard presents information on design, dimensions, tolerances, inspection, mounting, removal, and equipment that is common use with keyless tapered and keyless straight bore hubs for flexible couplings.

**ANSI/AGMA 9004-B08:** This standard presents information and calculation methods for the mass elastic properties and other characteristic.

**ANSI/AGMA 9006-A16:** Basis for ratings of standard flexible couplings.

## TYPES OF COUPLINGS

As mentioned in the Couplings introduction, there are two basic families of couplings, the Rigid and the Flexible. The Rigid Couplings are the most basic and cost effective and they are used when the shafts to be coupled are well aligned. Although there are different types of Rigid Couplings as the Flange, the Sleeve, the Compression, the Spline and others we present the Sleeve and the Flange types only.

As far as the Flexible Couplings family, they are grouped in two, the Material Flexing Couplings and the Mechanical Flexing Couplings.

The nomenclature we use to distinguish the type of couplings in this catalog is:

**Nomenclature:** To distinguish the different types of Couplings we use the following acronyms:

Rigid Couplings	<b>RC</b>
Flexible Couplings,	
<i>Material Flexible Couplings</i>	
Jaw Couplings	<b>L</b>
Hub Rubber Couplings	<b>HRC</b>
Sleeve Couplings	<b>SC</b>
Disc Couplings	<b>DC</b>
Diaphragm Couplings	<b>DHC</b>
Tire Couplings	<b>TC</b>
Grid Couplings	<b>GRC</b>
Oldham Couplings	<b>OC</b>
Pin Bush Couplings	<b>PB</b>
<i>Mechanical Flexing Couplings</i>	
Chain Couplings	<b>CC</b>
Gear Couplings	<b>GC</b>

### Rigid Couplings

These type of couplings provide a strong connection between the driving and driven shafts. They do not absorb any misalignment, thus they may be used in applications where the shafts are very well aligned. In such situations, these couplings offer a high performance with zero backlash. Are not recommended for high speed, as they cannot adjust for thermal changes in the shafts. They are indicated for vertical applications with uniform loads.

#### Clamp Type

Used in a wide variety of industrial applications, consists in a two-piece split alongside the axis, clamped by 4 or 6 high tensile bolts or socket head cap screws. This type of coupling stands up to high axial loads and display high torque capacity transmission without marring the shafts.

Available in Aluminum, Steel Casting and Stainless Steel, a wide choice of bores in Metric and Imperial and driving types either Plain Bore or Keyway.

Ask our Commercial Service for details on sizes.

There are many types of Rigid Couplings, namely the Flange, the Sleeve, the Clamp, the Ring compression, the Setscrew and the Spline. Out of these, we offer the Clamp, the Flange and the Ring Compression Couplings types. These latest types are presented in the Chapter B, Locking devices.



Two-piece Steel  
Clamp Coupling



Two-piece Stainless Steel  
Clamp Coupling

## Flange Type

They consist of two flanges, Male and Female bolted together thus backlash is not possible. The fixing to the shafts is by Keyway, or by Taper Bush. We offer the BTS, Keyway and Taper Bush versions.

The Taper Bush version permits two configurations obtained by fitting the Taper Bush on the Male Flange Hub side or on its Flange side while the Female Flange always receives the Taper Bush on its Flange side.

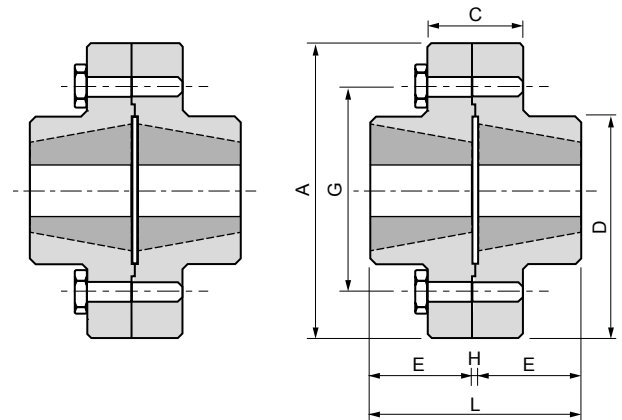

### Flange Type Rigid Coupling. Taper Bush

REFERENCE*	TAPER BUSH	BORE MAX.		A	C	D	E	G	H	J	L
		mm	inch								
TL-RC12	1210	32	32	118	35	83	25,50	102	7	38	58
TL-RC16	1615	42	42	127	43	80	38,00	105	7	38	83
TL-RC25	2517	60	60	178	51	123	45,00	149	7	48	97
TL-RC30	3030	75	75	216	65	146	76,00	181	7	54	159
TL-RC35	3535	100	100	248	75	178	89,00	213	7	67	185
TL-RC40	4040	110	110	298	76	210	102,00	257	7	79	211
TL-RC45	4545	125	125	330	86	230	114,00	286	7	89	235
TL-RC50	5050	125	125	362	92	266	127,00	314	7	92	261

\* All measures in mm unless otherwise indicated.

## Flexible Couplings

### Material Flexing Couplings

As mentioned, these type of couplings operate with an intermediate material in between the shafts from which the coupling attains the

flexibility. This material may be either an elastomer, metallic grid or disc.

### Jaw Couplings

Consist of two toothed hubs with a flexible element in between, the 'spider', which give to the set a 'flexing' capacity.

Jaw couplings are of elastomeric type whereas they transmit torque from the driving to the driven hubs through an elastomeric element, 'the spider'.

The elastomeric type couplings transmit the torque by compression or shear. Jaw couplings are of compression type whereas the driving hub pushes through the driven hub in the same plane compressing the elastomeric element.

The flexible element can have different Shore Hardness so to create a stiffer or softer connection between shafts. With the pressing of the toothed elements, the backlash it may be eliminated which for applications of precise positioning is very important. There are two versions, the straight and curved teeth.

This type of couplings are usually applied in electric motors with driven machinery as large industrial machines either pumps, blowers, compressors, mixers and others.

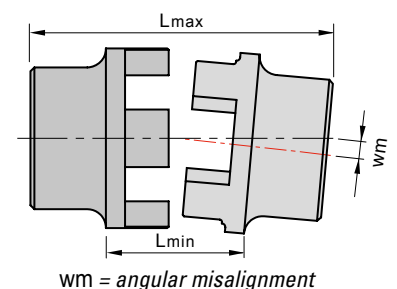
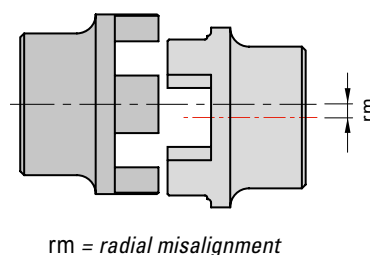
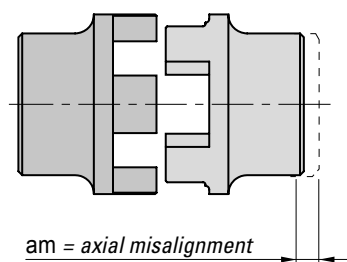

## Straight teeth

TYPE 1

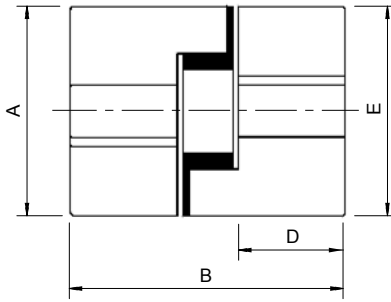

TYPE 2

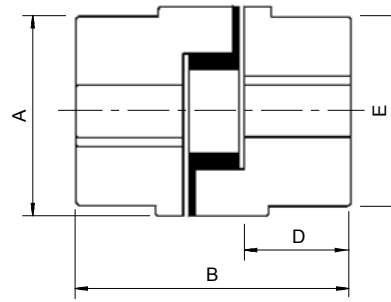

Stainless Steel Jaw Coupling Type 1



Jaw Coupling Keyway Type 2

### Elastomer properties

HARDNESS SHORE*	COLOR	PERMANENT TEMP RANGE	SHORT TERM TEMPERATURE
92SHA	Yellow	-40°C ~ 80°C	120°C
98SHA	Red	-40°C ~ 90°C	120°C
64SHD	Green	-40°C ~ 110°C	130°C

\* See Chapter L, page L3

### Jaw Couplings. Straight Teeth 'Spiders'

REFERENCE*	TYPE	A	B	D	E	BORE MM			BORE INCH	
						Standard	min	max	min	max
TL-L-035	1	19,00	15,60	6,60		3	3	8	1/8	3/8
TL-L-050	1	28,00	43,20	15,60		6	6	15	3/16	5/8
TL-L-070	1	35,00	50,80	19,00		9	9	19	3/16	3/4
TL-L-075	1	45,00	54,70	21,00		9	9	25	3/16	1
TL-L-090	1	54,00	54,70	21,00		9	9	28	3/16	1 1/8
TL-L-095	1	54,00	63,70	25,50		9	9	28	3/8	1 1/8
TL-L-099	1	64,50	72,50	27,00		12	12	35	7/16	1 3/8
TL-L-100	1	64,50	88,50	35,00		12	12	35	7/16	1 3/8
TL-L-110	1	85,00	108,00	43,00		15	15	48	1/2	1 7/8
TL-L-150	1	96,00	115,40	45,00		15	15	48	5/8	1 7/8
TL-L-190	2	115,00	133,40	54,00	101,60	19	19	55	5/8	2 1/4
TL-L-225	2	127,00	153,40	64,00	108,00	19	19	65	3/4	2 5/8

\* All measures in mm unless otherwise indicated.

### Service Factors

LOAD-TORQUE TYPE		PRIME MOVER		
		ELECTRIC MOTOR	RECIPROCATING ENGINES	
			> 6 pistons	< 6 pistons
LD	Light Duty	1,00	1,50	2,00
MD	Medium Duty	1,50	2,00	2,50
HD	Heavy Duty	2,00	2,50	3,00

### Jaw Couplings misalignment

SPIDER TYPE	TEMP. RANGE (°C)	MAX MISALIGNMENT ALLOW		POWER FACTOR
		wm°	pm mm	
NBR	-40 @ 100	1	0,38	1
Urethane	-35 @ 70	1	0,38	1
Hytrel	-50 @ 120	1/2	0,38	1,5
Bronze		1/2	0,25	3

## Elastomer Elements: "Spiders"

We have four choices: NBR<sup>1</sup>, Urethane<sup>2</sup>, Hytrel<sup>®3</sup> and Bronze.

**NBR**



**URETHANE**



**HYTREL**



**BRONZE**



### Power Ratings in kW with NBR elastomer

SPEED. REVS/MIN		JAW COUPLING SIZE										
		035	050	070	075	090	095	100	110	150	190	225
100		0,005	0,037	0,06	0,12	0,20	0,27	0,58	1,10	1,50	2,01	2,76
300		0,01	0,11	0,16	0,29	0,48	0,67	1,50	2,70	4,30	5,40	8,40
720		0,04	0,26	0,43	0,90	1,44	1,95	4,18	7,94	11,23	15,07	21,09
960		0,05	0,35	0,58	1,20	1,93	2,59	2,58	10,59	17,98	20,09	28,13
1200		0,05	0,45	0,63	1,16	1,97	2,70	5,90	10,70	17,00	21,50	32,20
1440		0,07	0,53	0,87	1,80	2,89	3,89	8,36	15,88	22,35	30,14	41,40
1800		0,10	0,70	0,90	1,87	3,00	4,00	8,90	16,10	25,50	32,20	48,30
2880		0,14	1,05	1,73	3,61	5,78	7,78	16,73	31,77	44,70	60,28	82,80
3600		0,18	1,30	2,17	4,51	7,22	9,73	20,91	39,71	51,00	64,40	96,60
Nominal	NBR	0,46	3,51	5,77	11,94	19,60	25,80	46,40	89,00	141,00	190,00	265,00
Torque. N.m	Hytrel		10,70	14,20	27,30	47,50	64,10	141,00	256,00	405,00	512,00	768,00

<sup>1</sup> Stands for **Nitrile Butadiene Rubber** and was developed in 1931 by the German IG Farben. Known Buna N as well is a synthetic rubber copolymer of Acrylonitrile and Butadiene. Is very resistant to oils, acids and alkaline. Has a Shore A Hardness from 30 to 90 and an UTS between 3,4 to 17,2 MPa and an elongation of 600% after fracture. When hydrogenated can reach to a UTS of 20 to 31 MPa. Stands to a temperature range from -40°C to 108°C and is highly resilient. Widely used, amongst other applications, transmissions belts, O-Rings, gaskets, oil seals and power elastomers.

<sup>2</sup> **Urethane**, derived from urea and ether was developed by IG Farbe in 1937. Known as well as Polyurethane as a result of adding urethane groups. There are many groups of urethanes, each one with specific properties. Generically, urethanes are resistant

to oils, to weather, to ozone and chemical agents. They have a high tensile and tear strength, abrasion resistance, high load bearing capacity, high impact resistance and resilience. Commonly used, amongst other applications in bonding hubs and bearings, rollers, Industrial wheels and castors, conveyor belts and in mechanical engineering in general.

<sup>3</sup> **Hytrel**. Thermoplastic polyester elastomer developed by Dupont. Highly performing after combining the features of elastomers and flexibility of plastic materials. It is tough, resistant to fatigue, to impact and to creeping. Stands up to a wide range of temperatures, resistant to chemicals and very versatile, as there is a wide choice of grades to adapt to a particular application. Has an operative temperature of -54°C to 121°C.

### Curved teeth

Unlike the previous series, this series incorporates curved jaws and elastomers. The curved concave jaws mesh with the convex spider's teeth with the result of improving the performance of the assembly as compared with the straight teeth.

This design provides a greater contact area between the spider and the jaws than the straight teeth equivalent what results in a greater

capacity of load transmission. It reduces the vibration, absorbs bigger misalignments and prolongs the life of the spider after avoiding edge stress due to the curvature.

Our program of curved teeth Jaw Couplings has three types, the Standard Type A, the Large Hub Type B and the Lengthened Hub Type C.

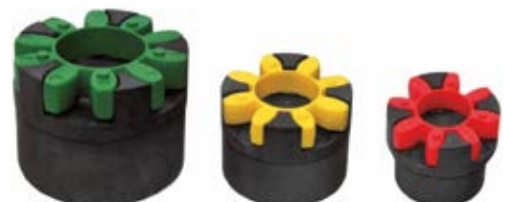
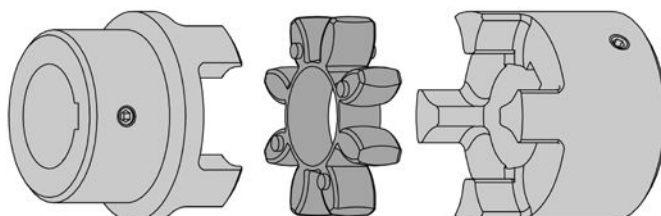

**STANDARD TYPE A**

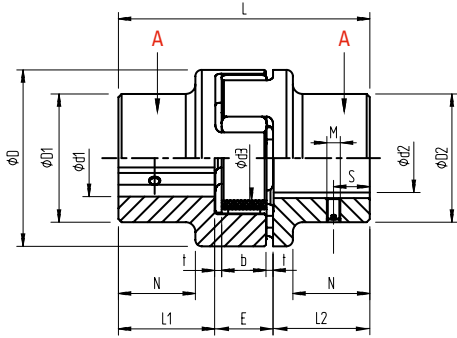

*Curved Teeth Jaw Coupling.  
Hub types AA*



*Hardness\* 92SHA  
Yellow Color  
Working temp range  
-40 °C @ +80 °C  
Instant temp 120 °C*

**LARGE HUB TYPE B: Oversize Type**

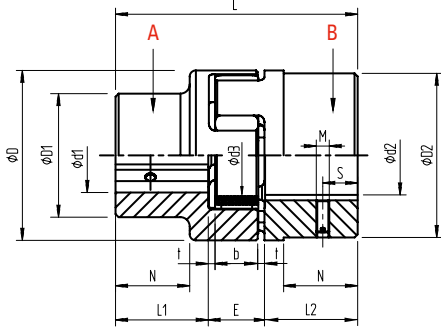

*Curved Teeth Jaw Coupling.  
Hub types BB*



*Hardness\* 98SHA  
Red Color  
Working temp range  
-40 °C @ +90 °C  
Instant temp 120 °C*

**HUB TYPE C: Lengthen Type**

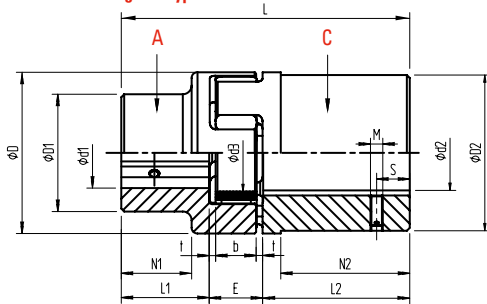

*Curved Teeth Jaw Coupling.  
Hub types AC*



*Hardness\* 64SHD  
Green Color  
Working temp range  
-40 °C @ +130 °C  
Instant temp 130 °C*

**Elastomer Specifications**

REFERENCE	MAXIMUM SPEED REVS/MIN		TORQUE N.m												
	CAST IRON	STEEL	92 SHA SHORE A*			98 SHA SHORE A*			64 SHA SHORE D*			92/98 SHA		64 SHD	
			Speed 35 m/s	Speed 40 m/s	Rated	Max	Alternate	Rated	Max	Alternate	Rated	Max	Alternate	α°	α° <sub>max</sub>
TL-E-LC14	22200	25400	7,5	15	2	12,5	25	3,3	16	32	4,2	6,4	10	4,5	7
TL-E-LC19	16700	19000	10	20	2,6	17	34	4,4	21	42	5,5	3,2	5	2,5	3,6
TL-E-LC24	12100	13800	35	70	9,1	60	120	16	75	150	19,5	3,2	5	2,5	3,6
TL-E-LC28	10100	11500	95	190	25	160	320	42	200	400	52	3,2	5	2,5	3,6
TL-E-LC38	8300	9500	190	380	49	325	650	85	405	810	105	3,2	5	2,5	3,6
TL-E-LC42	7000	8000	265	530	69	450	900	117	560	1120	146	3,2	5	2,5	3,6
TL-E-LC48	6350	7250	310	620	81	525	1050	137	655	1310	170	3,2	5	2,5	3,6
TL-E-LC55	5550	6350	410	820	107	685	1370	178	825	1650	215	3,2	5	2,5	3,6
TL-E-LC65	4950	5650	625	1250	163	940	1880	244	1175	2350	306	3,2	5	2,5	3,6
TL-E-LC75	4150	4750	1280	2560	333	1920	3840	499	2400	4800	624	3,2	5	2,5	3,6
TL-E-LC90	3300	3800	2400	4800	624	3600	7200	936	4500	9000	1170	3,2	5	2,5	3,6
TL-E-LC100	2950	3350	3300	6600	858	4950	9900	1287	6185	12370	1608	3,2	5	2,5	3,6
TL-E-LC110	2600	2950	4800	9600	1248	7200	14400	1872	9000	18000	2340	3,2	5	2,5	3,6
TL-E-LC125	2300	2600	6650	13300	1729	10000	20000	2600	12500	25000	3250	3,2	5	2,5	3,6
TL-E-LC140	2050	2350	8550	17100	2223	12800	25600	3328	16000	32000	4160	3,2	5	2,5	3,6
TL-E-LC160	1800	2050	12800	25600	3328	19200	38400	4992	24000	48000	6240	3,2	5	2,5	3,6
TL-E-LC180	1550	1800	18650	37300	4849	28000	56000	7280	36000	70000	9100	3,2	5	2,5	3,6

\* See page La3.

**Jaw Couplings Materials and Bores BTS. General Purpose**

REFERENCE	HUB	HUB TYPE	BORE DIAMETER IN MM . TOLERANCE HT . KEYWAY DIN 6885 C/W SETSCREW																																				
			6	8	9	10	11	12	14	15	16	17	18	19	20	22	24	25	26	28	30	32	35	38	40	42	45	48	50	55	60	65	70	75	80	85	90	100	
14	Sintered	B		√		√	√	√	√	√																													
19	Sintered	B								√		√		√	√	√	√	√																					
14	Aluminum	B	√	√	√	√	√	√	√	√	√	√	√	√	√	√	√																						
	Steel	B																																					
19	Aluminum	A				√	√	√	√	√	√	√	√	√																									
	Steel	B				√	√	√	√	√	√	√	√	√	√	√	√	√																					
24	Aluminum	A				√	√	√	√	√	√	√	√	√	√	√	√																						
	Steel	B				√		√	√	√	√	√	√	√	√	√	√	√	√																				
28	Aluminum	A				√	√		√		√	√	√	√	√	√	√																						
	Steel	B					√	√	√		√	√	√	√	√	√	√	√	√																				
38	Steel	A																																					
	Steel	B																																					
38	Casting	A									√		√	√	√	√	√	√	√	√																			
	Steel	B																																					
42	Steel	A																																					
	Steel	B																																					
42	Casting	A									√		√		√	√	√	√	√	√																			
	Steel	B																																					
48	Steel	A																																					
	Steel	B																																					
48	Casting	A																																					
	Steel	B																																					
55	Steel	A																																					
	Steel	B																																					
55	Casting	A																																					
	Steel	B																																					
65	Steel	A																																					
	Steel	B																																					
75	Steel	A																																					
	Steel	B																																					
90	Casting	A																																					
	Steel	A																																					
90	Casting	A																																					
	Steel	A																																					

**Nomenclature:** We identify this type of Jaw Couplings by -L-C- for Jaw Couplings – Curved as displayed in the tables of sizes ahead. There are available different choices on materials and treatments.

As materials, we offer the versions of, Steel, Stainless Steel, Cast Iron and Aluminum Jaw Hubs. As treatments we offer, Phosphating<sup>1</sup>, Black Oxide<sup>2</sup> and Anodizing<sup>3</sup>.

<sup>1</sup> See page Ma3.      <sup>2</sup> See page Ma4.      <sup>3</sup> See page Ma6.



## Jaw Couplings Series L-C. Material Aluminum

REFERENCE*	HUB	BORE d	L	L <sub>1</sub> L <sub>2</sub>	E	b	t	D	D <sub>1</sub> D <sub>2</sub>	N	d <sub>3</sub>	M	S	N
	Type	min - max												
TL-L-C14	B C	0 - 16	35 50	11 18,5	13	10	1,5	30	30	—	10	M4	5	1,5
TL-L-C19	B C	0 - 25	66 90	25 37	16	12	2	40	40	—	18	M5	10	2
TL-L-C24	B C	0 - 35	78 118	30 50	18	14	2	55	55	—	27	M5	10	2
TL-L-C28	B C	0 - 40	90 140	35 60	20	15	2,5	65	65	—	30	M8	15	10
TL-L-C38	A C	0 - 48	114 164	45 70	24	18	3	80	70 80	27	38	M8	15	10
TL-L-C42	A C	0 - 55	126 176	50 75	26	20	3	95	85 95	28	46	M8	20	10
TL-L-C48	A C	0 - 62	140 188	56 80	28	21	3,5	105	95 105	32	51	M8	20	10
TL-L-C55	A C	0 - 74	160 210	65 90	30	22	4	120	110 120	37	60	M10	20	17
TL-L-C65	A C	0 - 80	185 235	75 100	35	26	4,5	135	115 135	47	68	M10	20	17
TL-L-C75	A C	0 - 95	210 260	85 110	40	30	5	160	135 160	53	80	M10	25	17
TL-L-C90	A C	0 - 110	245 295	100 125	45	34	5,5	200	160 200	62	100	M12	30	40
TL-L-C100	A	50 - 115	270	110	50	38	6	225	160	89	113	M12	30	40
TL-L-C110	A	60 - 125	295	120	55	42	6,5	255	200	96	127	M16	35	80
TL-L-C125	A	60 - 145	340	140	60	46	7	290	230	11	147	M16	40	80
TL-L-C140	A	60 - 160	375	155	65	50	7,5	320	255	2124	165	M20	45	140
TL-L-C160	A	60 - 185	425	175	75	57	9	370	290	140	192	M20	50	140
TL-L-C180	A	85 - 200	475	195	85	64	10,5	425	325	155	220	M20	50	140

\* All measures in mm.

## GUIDE TO ORDER

**TL -**

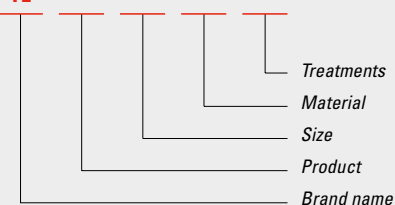

### Treatments:

**PH** Phosphating  
**BO** Black Oxide  
**AN** Anodizing

### Material:

**ST** Steel  
**SS** Stainless Steel  
**CI** Cast Iron  
**AL** Aluminum

### Size:

**L** 035 through 225  
**L-C** 14 through 180

### Product:

**JC** Jaw couplings  
Straight teeth  
**JC-C** Jaw couplings  
Curved teeth

**Brand name:**  
**TL-**

## HRC Couplings

Is an elastomeric type of Coupling, which has become a generic coupling name after its broadly use. Is a Hub-Rubber-Coupling type consisting of two cast-iron halves attached to shafts by means of either Hub or Flange Taper Bushes.

The two halves sandwich a flexible rubber-star-shaped, the 'spider' which acts as a shock absorber compensating vibrations and misalignments. The range of use goes to Taper Bushes up to 90 mm bore or shafts up to 130 mm when bored with keyway.

These type of couplings are for general purpose, are indicated for high-speed operation, behave very well absorbing shocks, but at the side of compensating misalignments, they do not respond as much

as with the shocks, accommodating parallel misalignments up to 0,5 mm and axial misalignments up to 1,7 mm. Are very useful in situations of high acceleration/deceleration motion due to their capacity to absorb shocks. It is of interest mentioning the isolating effect of the electric motor from driven equipment.

Our program have MPB and Taper Bush versions.

As mentioned, this type of couplings have a good response to shocks, but the intensity of shocks, the vibration and torque variations will determine the appropriate model to use in the particular application and consequently the Service Factor attached to every application is of high importance.

### Service Factors

DRIVEN TYPE OF MOVEMENT*	PRIME MOVERS					
	ELECTRIC MOTORS - STEAM TURBINES			COMBUSTION ENGINES - WATER TURBINES		
	DAILY WORKING HOURS					
	< 8	8 to 16	< 16	< 8	8 to 16	< 16
<b>Uniform type of movement</b>						
Agitators, Brewing machinery	1,00	1,12	1,26	1,25	1,40	1,60
Centrifugal Blowers, Fans and Pumps						
Conveyors, Generators						
<b>Moderate shock type of movement</b>						
Crane Hoists, Clay Machinery						
Laundry Machinery, Machine Tools	1,60	1,80	2,00	2,00	2,24	2,50
Textile Machinery and others						
<b>High Shock type of movement</b>						
Crushers, Shakers, Metal Mills						
Banburies, Machine Tools	2,50	2,80	3,12	3,12	3,55	4,00
Reciprocating Compressors						

\* The Service Factors in this table have to be used as a guide, and adapted to the particular application.



HRC MPB version



HRC. Taper Bush type version

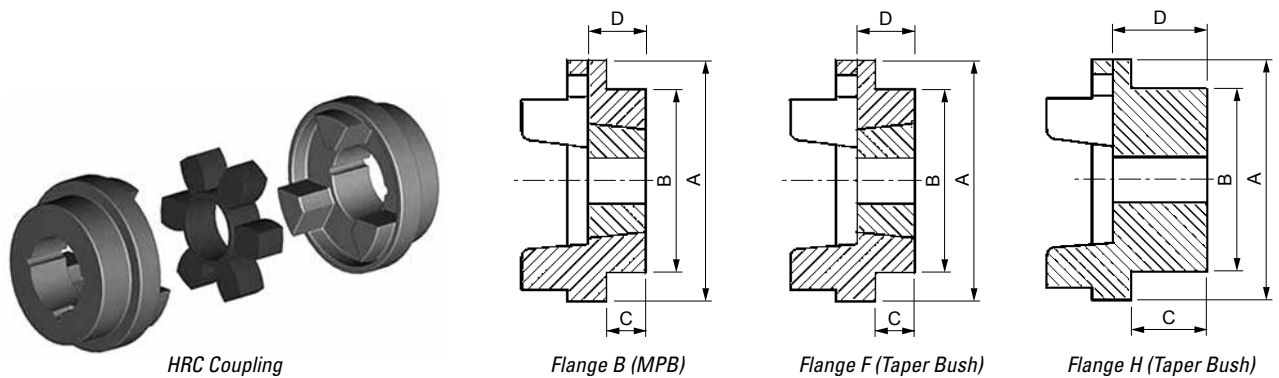

### Assembly F&H Flanges

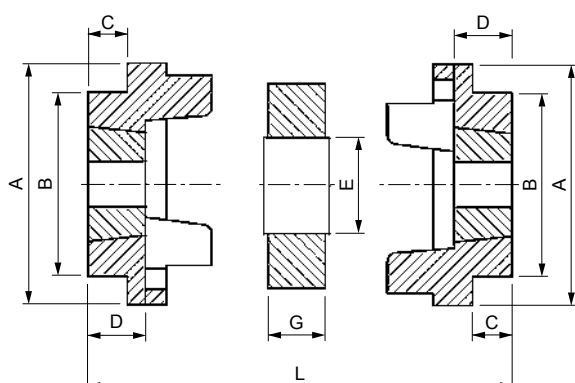

### Assembly B Flanges

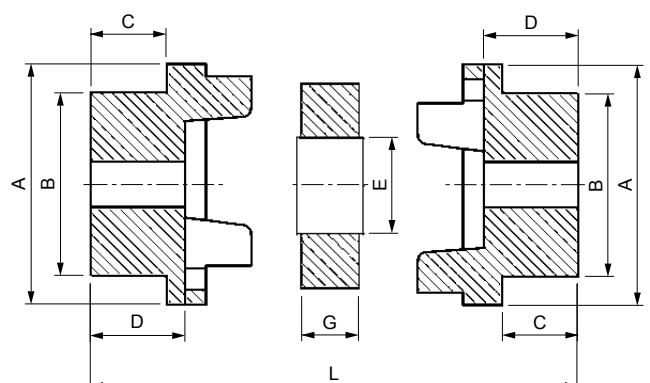

## HRC Couplings Sizes

HRC COUPLING REFERENCE*	A	B	E	G	FLANGE HUB TYPE F&H						FLANGE HUB TYPE B					POWER IN kW TRANSMITTED AT 1000 rpm		
					BORE		TAPER BUSH	C	D	F	L	BORE		C	D		F	L
					MPB	max						MPB	max					
TL-HRC70	69,00	60,00	31,00	18,00	9,00	25,00	1008	20,00	24,00	26,00	66,00	10,00	32,00	20,00	24,00	26,00	66,00	0,33
TL-HRC90	85,00	70,00	32,00	22,50	9,00	28,00	1108	19,50	24,00	31,50	70,50	10,00	35,00	26,00	30,00	30,50	82,50	0,84
TL-HRC110	112,00	100,00	45,00	29,00	11,00	32,00	1610	18,50	27,00	46,00	83,00	10,00	55,00	37,00	45,00	45,00	119,00	1,68
TL-HRC130	130,00	105,00	50,00	36,00	14,00	42,00	1610	18,00	27,00	54,00	90,00	60,00	60,00	47,00	56,00	54,00	148,00	3,30
TL-HRC150	150,00	115,00	62,00	40,00	14,00	50,00	2012	23,50	34,00	61,00	108,00	70,00	70,00	50,00	60,00	60,00	160,00	6,28
TL-HRC180	180,00	125,00	77,00	49,00	16,00	60,00	2517	34,50	47,00	74,00	143,00	80,00	80,00	58,00	70,00	73,00	189,00	9,95
TL-HRC230	225,00	155,00	99,00	59,50	25,00	75,00	3020	39,50	53,00	86,50	165,50	100,00	100,00	77,00	90,00	85,50	239,50	20,90
TL-HRC280	275,00	206,00	119,00	74,50	35,00	90,00	3525	51,00	67,00	106,50	208,50	115,00	115,00	90,00	105,00	104,50	284,50	33,00

\* All measures in mm.

## Standard Electric Motors

THREE PHASE MOTOR	SHAFT DIA	MOTOR REVS 3000		MOTOR REVS 1500		MOTOR REVS 1000		MOTOR REVS 750	
		MOTOR POWER	COUPLING	MOTOR POWER	COUPLING	MOTOR POWER	COUPLING	MOTOR POWER	COUPLING
Size	mm	kW	Size	kW	Size	kW	Size	kW	Size
90S	24	1,5	70	1,1	70	0,75	70		
90L	24	2,2	70	1,5	70	1,1	70		
112M	28	4	90	4	90	2,2	90		
132S	38	5,5	110 A	5,5	110A	3	110A	2,2	110A
		7,5	110 A						
132M	38			7,5	110A	4	110A	3	110A
						5,5	110A		
160M	42	11	110 A	11	110A	7,5	110A	4	110A
		15	110 A					5,5	110A
160L	42	18,5	110 A	15	110A	11	130	7,5	110A
180M	48	22	150	18,5	150				
180L	48			22	150	15	150	11	150
200L	55	30	180						
		37	180			22	180		
225S	60			37	180			18,5	180
225M	55*	45	180	45	180	30	180	22	180
	60								
250M	60*	55	180	55	230	37	230	30	230
	65								
280S	75			75	230	45	230	37	230
280M	75			90	230	55	230	37	230
315S	80			110	280	75	280	55	280
315M	80			132	280	90	280	75	280

\* 3000 revs only.

### Power Ratings

REVS/ MIN	HRC COUPLING SIZE							
	70	90	110	130	150	180	230	280
100	0,33	0,84	1,68	3,30	6,28	9,95	20,90	33,00
200	0,66	1,68	3,35	6,60	12,60	19,90	41,90	66,00
400	1,32	3,35	6,70	13,20	25,10	39,80	83,80	132,00
600	1,98	5,03	10,10	19,80	37,70	59,70	126,00	198,00
720	2,37	6,03	12,10	23,80	45,20	71,60	151,00	238,00
800	2,64	6,70	13,40	26,40	50,30	79,60	168,00	264,00
960	3,17	8,40	16,10	31,70	60,30	95,50	201,00	317,00
1200	3,96	10,10	20,10	39,60	75,40	119,00	251,00	396,00
1440	4,75	12,10	24,10	47,50	90,50	143,00	302,00	475,00
1600	5,28	13,40	26,80	52,80	101,00	159,00	335,00	528,00
1800	5,94	15,10	30,20	59,40	113,00	179,00	377,00	594,00
2000	6,60	16,80	33,50	66,00	126,00	199,00	419,00	660,00
2200	7,26	18,40	36,90	72,60	138,00	219,00	461,00	
2400	7,92	20,10	40,20	79,20	151,00	239,00	503,00	
2600	8,58	21,80	43,60	85,80	163,00	259,00	545,00	
2880	9,50	24,10	48,30	95,00	181,00	286,00		
3000	9,90	25,10	50,30	99,00	188,00	298,00		
3600	11,90	30,10	60,30	118,00	226,00			

### HRC Specs

SPECS	HRC COUPLING SIZE							
	70	90	110	130	150	180	230	280
Maximum speed revs/min	8300	6740	5110	4400	3800	3180	2540	2080
Nominal Torque N.m	32	80	160	315	600	950	2000	3150
Maximum Parallel Misalignment mm	0,30	0,30	0,30	0,40	0,40	0,40	0,50	0,50
Maximum Axial Misalignment mm	0,20	0,50	0,60	0,80	0,90	1,10	1,30	1,70

### GUIDE TO ORDER

#### Flanges:

#### TL - HRC

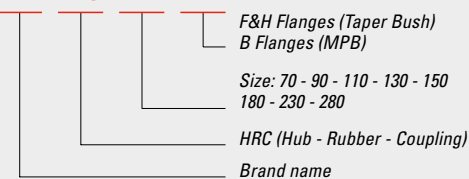

#### Assemblies:

#### TL - HRC

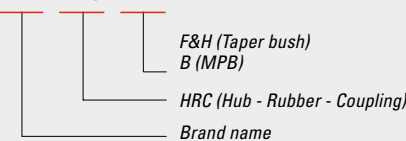

### Sleeve Couplings

Known as well as the S-Flex couplings, consist of two hubs or flanges with a flexible sleeve sitting in between the two hubs. The flanges with internal teeth mesh with the external teeth of the sleeve, which transmits torque through its shearing.

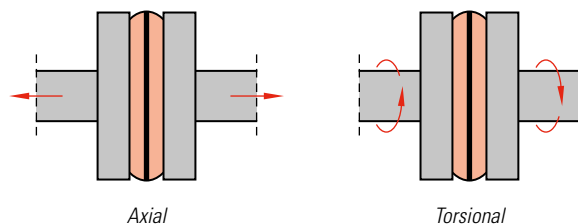

**Axial:** This type of coupling has a limited capacity to absorb axial misalignments. In reverse, it minimizes the thrust load transmitted to bearings.

**Torsional:** The material of the elastomer and its design is well suited to absorb angular misalignments, shocks and lessens the vibration.

This type of coupling absorbs well the misalignments and torsional shock loads, by shear deflection in the sleeve and is able to transmit average torques ranging from 6,8 N.m to 8170 N.m. This type of couplings do not need maintenance nor lubrication and are of easy installation.

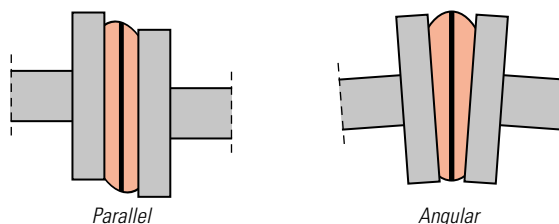

**Parallel:** The parallel misalignment varies according the size, from 0,38 mm to 1,5 mm.

**Angular:** Due to the flexing capacity it adjusts well to angular misalignments up to 1°.

We have a choice of highly performing sleeves, EPDM<sup>1</sup>, Neoprene and Hytrel<sup>®2</sup>. EPDM and Neoprene admit a torsion flex of 15°, and Hytrel a much less, 7°. In revenge, Hytrel transmits around four times as much power as the equivalent EPDM or Neoprene. There are two Series available, the J and the S.

At the time of choosing the best adapted size for the power transmission application, it is important to ascertain the type of load-torque transmitted and in consequence apply a service factor accordingly. We distinguish three service factor levels as, light, medium and heavy.

### Service Factors

TYPE OF LOAD-TORQUE	STANDARD TORQUE ELECTRIC MOTOR	HIGH TORQUE ELECTRIC MOTOR	TURBINES	RECIPROCATING ENGINES
LD Light Duty	1,25	1,50	1,00	1,50
MD Medium Duty	1,50	2,00	1,25	2,00
HD Heavy Duty	2,00	2,50	1,50	2,50



### Serie J

REFERENCE*	D	BORE		C	E	G	B	L	H	M
		min	max							
TL-SC-3J	52,40	9,00	22,20	20,60	11,10	9,50	38,10	50,80	9,50	14,30
TL-SC-4J	62,50	12,00	25,40	22,20	11,10	15,90	41,30	60,30	11,10	14,30
TL-SC-5J	82,60	12,00	28,60	27,00	11,90	19,10	47,60	73,00	15,10	19,10
TL-SC-6J-1	101,60	15,00	31,80	31,00	15,10	22,20	49,20	84,20	15,90	24,60
TL-SC-6J-2	101,60	15,00	34,90	31,00	15,10	22,20	63,50	84,20	15,90	27,80
TL-SC-6J-3	101,60	15,00	44,50	33,30	13,50	22,20	63,50	88,90	19,80	27,80
TL-SC-6J-4	101,60	15,00	47,60	39,70	19,80	22,20	71,40	101,60	19,80	27,80
TL-SC-8J	138,40	18,00	60,30	49,20	26,20	28,60	82,60	127,00	23,00	38,10
TL-SC-9J	161,30	22,00	73,00	57,90	31,80	36,50	104,80	152,40	26,20	44,50
TL-SC-10J	190,50	28,00	85,70	68,30	37,30	41,30	120,70	177,80	30,90	50,80
TL-SC-11J	219,10	30,00	98,40	77,80	39,70	47,80	142,90	203,30	38,10	60,50

\* All measures in mm unless otherwise indicated.

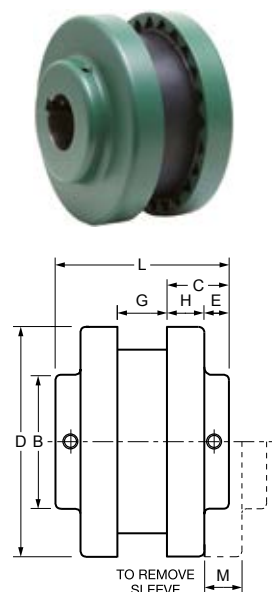

### Serie S

REFERENCE*	D	BORE		C	E	G	B	L	H	M
		min	max							
TL-SC-5S	82,60	12,00	31,80	34,10	11,50	19,10	47,60	72,20	15,10	24,60
TL-SC-6S	101,60	15,00	38,10	41,30	14,30	22,20	63,50	90,50	19,80	27,80
TL-SC-7S	117,50	16,00	47,60	46,80	17,50	25,40	71,40	100,00	19,80	33,30
TL-SC-8S	138,40	18,00	57,20	53,20	19,10	28,60	82,60	112,70	23,00	38,10
TL-SC-9S	161,30	22,00	63,50	61,10	19,80	36,54	92,10	128,60	26,20	44,50
TL-SC-10S	190,50	28,00	79,40	67,50	20,60	41,30	111,10	144,40	30,90	50,80
TL-SC-11S-1	219,10	30,00	57,20	87,30	28,60	47,80	95,30	181,10	38,10	60,50
TL-SC-11S-2	219,10	30,00	73,00	87,30	28,60	47,80	123,80	181,10	38,10	60,50
TL-SC-11S-3	219,10	30,00	92,10	87,30	28,60	47,80	133,40	181,10	38,10	60,50
TL-SC-12S-1	254,00	38,00	57,20	101,60	32,50	58,70	95,30	209,50	42,90	68,30
TL-SC-12S-2	254,00	38,00	73,00	101,60	32,50	58,70	123,80	209,50	42,90	68,30
TL-SC-12S-3	254,00	38,00	100	101,60	32,50	58,70	146,10	209,50	42,90	68,30
TL-SC-13S-1	298,50	50,00	73,00	111,10	33,30	68,30	123,80	235,00	50,00	77,70
TL-SC-13S-2	298,50	50,00	114,30	111,10	33,30	68,30	171,50	235,00	50,00	77,70
TL-SC-14S-1	352,40	50,00	73,00	114,30	27,00	82,60	123,80	250,90	57,20	88,90
TL-SC-14S-2	352,40	50,00	127,00	114,30	27,00	82,60	190,50	250,90	57,20	88,90

\* All measures in mm.

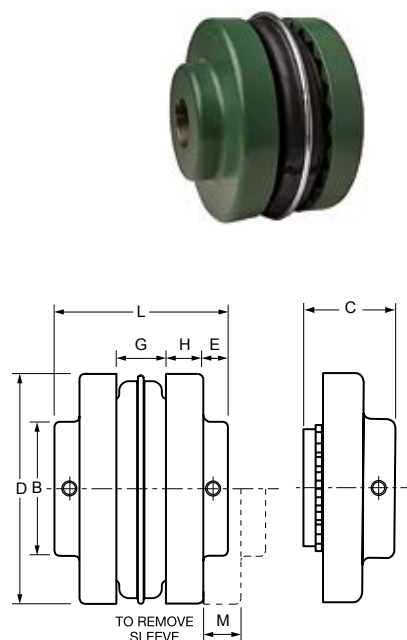

<sup>1</sup> EPDM. Ethylene, Propylene, Diene, Monomer. Synthetic elastomer of SHA hardness from 50 to 65, Tensile strength from 3 to 14 MPa according grade. Mainly used as elastomer in external applications. Resists to aging, ozone, UV rays, water and environmental action. Resist to abrasion, to acids, alkaline and a range of temperature from -40°C to 120°C.

<sup>2</sup> Hytrel. Thermoplastic polyester elastomer developed by Dupont. Highly performing after combining the features of elastomers and flexibility of plastic materials. It is tough, resistant to fatigue, to impact and to creeping. Stands up to a wide range of temperatures, resistant to chemicals and very versatile, as there is a wide choice of grades to adapt to a particular application. Has an operative temperature of -54°C to 121°C.

## Power Ratings

COUPLING SIZE	ELASTOMER	POWER RATING IN kW PER GIVEN RPM*										RATED TORQUE N.M
		100	250	500	725	950	1450	2000	2500	2850	3500	
3	EPDM	0,07	0,18	0,35	0,51	0,67	1,00	1,40	1,80	2,00	2,50	34,10
4	EPDM	0,14	0,35	0,71	1,03	1,35	2,10	2,80	3,50	4,00	5,00	41,30
5	EPDM	0,28	0,71	1,42	2,06	2,70	4,10	5,70	7,10	8,10	9,90	46,80
6	EPDM	0,53	1,33	2,66	3,86	5,06	7,70	10,60	13,30	15,20	18,60	53,20
7	EPDM	0,86	2,14	4,29	6,22	8,15	12,40	17,20	21,40	24,40	30,00	61,10
8	EPDM	1,34	3,36	6,71	9,73	12,76	19,50	26,90	33,60	38,30	47,00	67,50
9	EPDM	2,13	5,32	10,65	15,44	20,23	30,90	42,60	53,20	60,70	74,50	87,30
10	EPDM	3,40	8,50	17,01	24,66	32,31	49,30	68,00	85,00	96,90	119,00	87,30
11	EPDM	5,40	13,40	26,80	38,90	50,90	77,70	107,20	134,00	152,70	187,60	87,30
12	EPDM	8,50	21,30	42,60	61,80	80,90	123,50	170,40	212,90			101,60
13	EPDM	13,40	33,60	67,10	97,30	127,60	194,70	268,50	335,70			101,60
14	EPDM	21,30	53,20	106,50	154,40	202,30	308,80	425,90				101,60
6	HYTREL	2,10	5,30	10,60	15,40	20,20	30,90	42,60	53,20	60,70	74,50	111,10
7	HYTREL	3,40	8,50	17,00	24,70	32,30	49,30	68,00	85,00	96,90	119,00	111,10
8	HYTREL	5,50	13,70	27,40	39,70	52,00	79,40	109,50	136,90	156,10	191,70	114,30
9	HYTREL	8,50	21,30	42,60	61,80	80,90	123,50	170,40	212,90	242,80	298,10	114,30
10	HYTREL	13,40	33,60	67,10	97,30	127,60	194,70	268,50	335,70	382,70	470,00	
11	HYTREL	21,30	53,20	106,50	154,40	202,30	308,80	425,90	532,40	606,90	745,30	
12	HYTREL	37,30	93,20	186,30	270,20	354,00	540,40	745,30	931,60			
13	HYTREL	55,90	139,80	279,60	405,40	531,20	810,80	1118,40				
14	HYTREL	85,70	214,40	428,70	621,70	814,60	1243,30					

\* Measured at 24°C.



Split Elastomer Type J



Split Elastomer Type S

## GUIDE TO ORDER

**TL - SC**

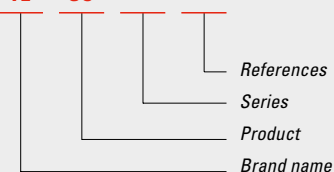

**Size:**  
3 through 11  
5 through 14

**Series:**  
J  
S

**Type:**  
SC Sleeve Coupling

**Brand name:**  
TL

## Disc Couplings

These couplings transmit the torque by means of driving bolts, which pull the driven bolts on the same bolt circle. They have driving and driven bolts with a disc. The more bolts installed the greater the tor-

que transmitted, but the flexibility needed and the loads are keen to determine the number of bolts. They absorb misalignments of most shaft situations.

### Series DC, Single and Double

Made out of high strength aluminum alloy body and the diaphragm of high strength spring stainless steel, providing high torsional stiffness, a low moment of inertia and resistance to high temperatures.

Offered in two versions of Single, coded as O, and Double Diaphrag-

ms, coded as T.

Main applications: Machine tools, Textile machinery, Printing presses and in general used in applications of high speed, high transmission accuracy and low moment of inertia.

## Series DC Single

DC 0-A

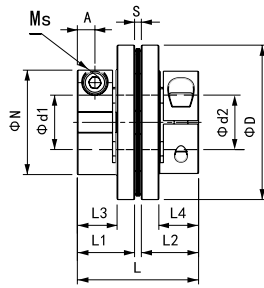

DC 0-B

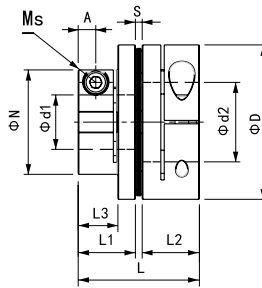

DC 0-C

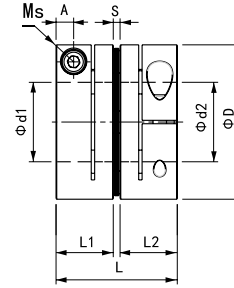

REFERENCE*	d <sub>1</sub>		d <sub>2</sub>		D	N	t	L <sub>1</sub>	L <sub>2</sub>	L <sub>3</sub>	L <sub>4</sub>	S	A	P**	M <sub>s</sub>	LOCKING TORQUE
	min	max	min	max												
TL-DC-005-O-C	3	6	3	6	16,00		16,60	7,85	7,85			0,90	2,50	6,50	M2	0,4 - 0,5
TL-DC-010-O-C	3	8	3	8	19,00		19,20	9,15	9,15			0,90	3,15	8,50	M2	0,4 - 0,5
TL-DC-020-O-C	4	10	4	11	26,00		23,00	10,75	10,75			1,50	3,30	10,50	M2.5	1,0-1,1
TL-DC-025-O-C	5	14	5	14	29,00		23,30	10,75	10,75			1,80	3,30	14,50	M2.5	1,0-1,1
TL-DC-030-O-A	5	10	5	10	34,00	21,60	27,40	12,40	12,40	8,90	8,90	2,60	3,80	14,50	M3	1,5-1,9
TL-DC-030-O-B	5	10	5	16	34,00	21,60	27,40	12,40	12,40	8,90		2,60	3,80	14,50	M3	1,5-1,9
TL-DC-030-O-C	5	14	5	16	34,00		27,40	12,40	12,40			2,60	3,80	14,50	M3	1,5-1,9
TL-DC-035-O-C	6	16	6	18	39,00		34,20	15,50	15,50			3,20	4,50	17,00	M4	3,4-4,1
TL-DC-040-O-A	8	15	8	15	44,00	29,60	34,20	15,50	15,50	10,50	10,50	3,20	4,50	19,50	M4	3,4-4,1
TL-DC-040-O-B	8	15	8	22	44,00	29,60	34,20	15,50	15,50	10,50		3,20	4,50	19,50	M4	3,4-4,1
TL-DC-040-O-C	8	22	8	22	44,00		34,20	15,50	15,50			3,20	4,50	19,50	M4	3,4-4,1
TL-DC-050-O-A	8	19	8	19	56,00	38,00	43,40	20,50	20,50	14,00	14,00	2,40	6,00	26,00	M5	7,0-8,5
TL-DC-050-O-B	8	19	8	30	56,00	38,00	43,40	20,50	20,50	14,00		2,40	6,00	26,00	M5	7,0-8,5
TL-DC-050-O-C	8	25	8	30	56,00		43,40	20,50	20,50			2,40	6,00	26,00	M5	7,0-8,5
TL-DC-060-O-A	11	24	11	24	68,00	46,00	53,40	25,20	25,20	17,50	17,50	3,00	7,75	31,00	M6	14-15
TL-DC-060-O-B	11	24	11	35	68,00	46,00	53,40	25,20	25,20	17,50		3,00	7,75	31,00	M6	14-15
TL-DC-060-O-C	11	30	11	35	68,00		53,40	25,20	25,20			3,00	7,75	31,00	M6	14-15
TL-DC-080-O-C	18	35	18	40	82,00		68,00	30,00	30,00			8,00	9,00	38,00	M8	27-30
TL-DC-090-O-C	25	40	25	45	94,00		68,30	30,00	30,00			8,30	9,00	42,00	M8	27-30
TL-DC-100-O-C	32	45	32	45	104,00		69,80	30,00	30,00			9,80	9,00	48,00	M8	27-30

\* All measures in mm.

\*\* Diaphragm center distance in mm.

REFERENCE*	MAX TORQUE	MAX SPEED	TORSIONAL RIGIDITY	AXIAL RIGIDITY	WEIGHT
	N.m	rpm	N.m/rad	N/mm	Kg
TL-DC-005-O-C	0,6	10000	500	140	0,007
TL-DC-010-O-C	1	10000	1400	140	0,011
TL-DC-020-O-C	2	10000	3700	64	0,025
TL-DC-025-O-C	4	10000	5600	60	0,030
TL-DC-030-O-A	5	10000	8000	64	0,035
TL-DC-030-O-B	5	10000	8000	64	0,041
TL-DC-030-O-C	5	10000	8000	64	0,050
TL-DC-035-O-C	8	10000	18000	112	0,086
TL-DC-040-O-A	10	10000	20000	80	0,079
TL-DC-040-O-B	10	10000	20000	80	0,090
TL-DC-040-O-C	10	10000	20000	80	0,105
TL-DC-050-O-A	25	10000	32000	48	0,164
TL-DC-050-O-B	25	10000	32000	48	0,182
TL-DC-050-O-C	25	10000	32000	48	0,213
TL-DC-060-O-A	60	10000	70000	76	0,286
TL-DC-060-O-B	60	10000	70000	76	0,331
TL-DC-060-O-C	60	10000	70000	76	0,392
TL-DC-080-O-C	100	10000	140000	128	0,736
TL-DC-090-O-C	180	10000	100000	108	0,973
TL-DC-100-O-C	250	10000	120000	111	1,229



## Series DC Double

DC T-A

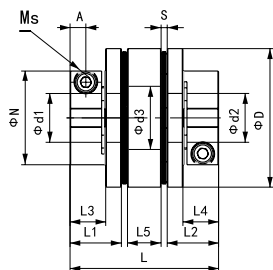

DC T-B

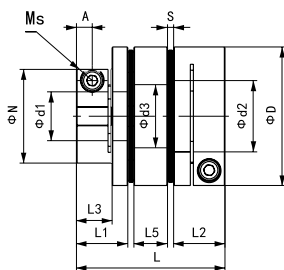

DC T-C

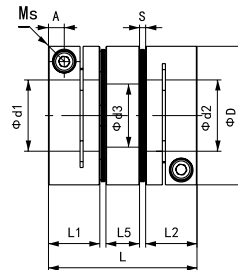

REFERENCE*	d <sub>1</sub>		d <sub>2</sub>		d <sub>3</sub>	D	N	L	L <sub>1</sub>	L <sub>2</sub>	L <sub>3</sub>	L <sub>4</sub>	L <sub>5</sub>	S	A	P**	M <sub>s</sub>	LOCKING TORQUE	
	min	max	min	max															N.m
TL-DC2-005-T-C	3	6	3	6	6,5	16,00		23,60	7,85	7,85				6,10	0,90	2,50	6,50	M2	0,4 - 0,5
TL-DC2-010-T-C	3	8	3	8	8,5	19,00		19,20	9,15	9,15				6,20	0,90	3,15	8,50	M2	0,4 - 0,5
TL-DC2-020-T-C	4	10	4	11	11	26,00		26,30	10,75	10,75				9,10	1,50	3,30	10,50	M2.5	1,0-1,1
TL-DC2-025-T-C	5	14	5	14	15	29,00		33,60	10,75	10,75				8,50	1,80	3,30	14,50	M2.5	1,0-1,1
TL-DC2-030-T-A	5	10	5	10	15	34,00	21,60	33,60	12,40	12,40	8,90	8,90	8,00	2,60	3,80	14,50	M3	1,5-1,9	
TL-DC2-030-T-B	5	10	5	16	15	34,00	21,60	38,00	12,40	12,40	8,90		8,00	2,60	3,80	14,50	M3	1,5-1,9	
TL-DC2-030-T-C	5	14	5	16	15	34,00		38,00	12,40	12,40			8,00	2,60	3,80	14,50	M3	1,5-1,9	
TL-DC2-035-T-C	6	16	6	18	17	39,00		38,00	15,50	15,50			11,00	3,20	4,50	17,00	M4	3,4-4,1	
TL-DC2-040-T-A	8	15	8	15	20	44,00	29,60	48,40	15,50	15,50	10,50	10,50	11,00	3,20	4,50	19,50	M4	3,4-4,1	
TL-DC2-040-T-B	8	15	8	22	20	44,00	29,60	48,40	15,50	15,50	10,50		11,00	3,20	4,50	19,50	M4	3,4-4,1	
TL-DC2-040-T-C	8	22	8	22	20	44,00		48,40	15,50	15,50			11,00	3,20	4,50	19,50	M4	3,4-4,1	
TL-DC2-050-T-A	8	19	8	19	26	56,00	38,00	48,40	20,50	20,50	14,00	14,00	14,00	2,40	6,00	26,00	M5	7,0-8,5	
TL-DC2-050-T-B	8	19	8	30	26	56,00	38,00	59,80	20,50	20,50	14,00		14,00	2,40	6,00	26,00	M5	7,0-8,5	
TL-DC2-050-T-C	8	25	8	30	26	56,00		59,80	20,50	20,50			14,00	2,40	6,00	26,00	M5	7,0-8,5	
TL-DC2-060-T-A	11	24	11	24	31	68,00	46,00	72,90	25,20	25,20	17,50	17,50	16,50	3,00	7,75	31,00	M6	14-15	
TL-DC2-060-T-B	11	24	11	35	31	68,00	46,00	72,90	25,20	25,20	17,50		16,50	3,00	7,75	31,00	M6	14-15	
TL-DC2-060-T-C	11	30	11	35	31	68,00		72,90	25,20	25,20			16,50	3,00	7,75	31,00	M6	14-15	
TL-DC2-080-T-C	18	35	18	40	40	82,00		101,00	30,00	30,00			25,00	8,00	9,00	38,00	M8	27-30	
TL-DC2-090-T-C	25	40	25	45	47	94,00		101,60	30,00	30,00			25,00	8,30	9,00	42,00	M8	27-30	
TL-DC2-100-T-C	32	45	32	45	50	104,00		104,60	30,00	30,00			25,00	9,80	9,00	48,00	M8	27-30	

\* All measures in mm.

\*\* Diaphragm center distance in mm.

REFERENCE*	MAX TORQUE	MAX SPEED	TORSIONAL RIGIDITY	AXIAL RIGIDITY	WEIGHT
	N.m	rpm	N.m/rad	N/mm	Kg
TL-DC2-005-T-C	0,6	10000	250	70	0,011
TL-DC2-010-T-C	1	10000	700	70	0,016
TL-DC2-020-T-C	2	10000	1850	32	0,038
TL-DC2-025-T-C	4	10000	2800	30	0,043
TL-DC2-030-T-A	5	10000	4000	32	0,055
TL-DC2-030-T-B	5	10000	4000	32	0,620
TL-DC2-030-T-C	5	10000	4000	32	0,070
TL-DC2-035-T-C	8	10000	9000	56	0,127
TL-DC2-040-T-A	10	10000	10000	40	0,127
TL-DC2-040-T-B	10	10000	10000	40	0,139
TL-DC2-040-T-C	10	10000	10000	40	0,154
TL-DC2-050-T-A	25	10000	16000	24	0,259
TL-DC2-050-T-B	25	10000	16000	24	0,277
TL-DC2-050-T-C	25	10000	16000	24	0,308
TL-DC2-060-T-A	60	10000	35000	38	0,451
TL-DC2-060-T-B	60	10000	35000	38	0,495
TL-DC2-060-T-C	60	10000	35000	38	0,556
TL-DC2-080-T-C	100	10000	70000	64	1,102
TL-DC2-090-T-C	180	10000	50000	54	1,444
TL-DC2-100-T-C	250	10000	60000	55,5	1,827

\* All measures in mm.





## Series DC-A. Single and Double

Made out of carbon steel body and disc of high strength spring steel for a high torsional stiffness.

Offered in two versions of Single, coded as O, and Double disc, co-

ded as T.

Main applications, in compressors, pumps, mixer and in other high load situations.

### Series DC-A Single

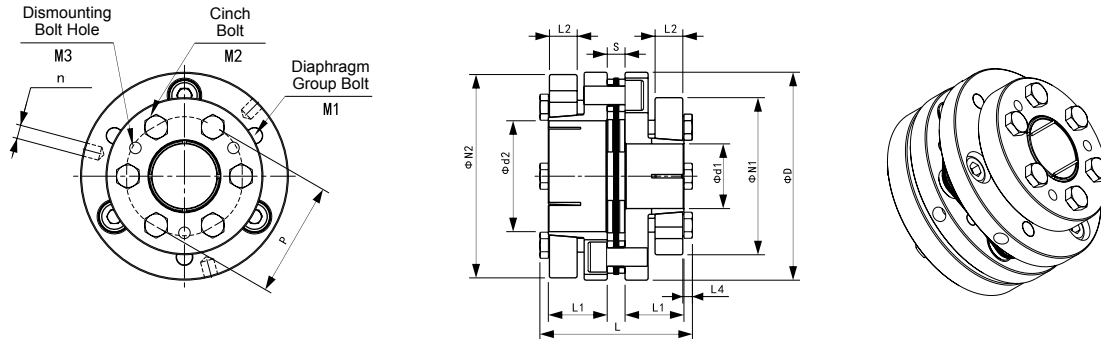

REFERENCE*	D	L	d <sub>1</sub> /d <sub>2</sub>	N <sub>1</sub> /N <sub>2</sub>	L <sub>1</sub>	L <sub>2</sub>	L <sub>4</sub>	S	P	n	M <sub>1</sub>	LOCKING TORQUE	M <sub>2</sub>	LOCKING TORQUE	M <sub>3</sub>
												N.m		N.m	
TL-DC-A070-0-A-	70	60,50	18-19	53	23,50	12,00	4,00	6,50	31,00	4 x 5,10	M6	14,00	4 X M6	12,00	2 x M6
TL-DC-A070-0-A-	70	60,50	20-22-24-25	58	23,50	12,00	4,00	6,50	31,00	4 x 5,10	M6	14,00	4 X M6	12,00	2 x M6
TL-DC-A070-0-A-	70	60,50	28-30	63	23,50	12,00	4,00	6,50	31,00	4 x 5,10	M6	14,00	4 X M6	12,00	2 x M6
TL-DC-A070-0-A-	70	60,50	32-35	68	23,50	12,00	4,00	6,50	31,00	4 x 5,10	M6	14,00	4 X M6	12,00	2 x M6
TL-DC-A080-0-A-	80	66,30	22-24-25	58	25,50	12,00	4,00	8,30	37,00	4 x 5,10	M8	34,00	4 X M6	12,00	2 x M6
TL-DC-A080-0-A-	80	66,30	28-30	63	25,50	12,00	4,00	8,30	37,00	4 x 5,10	M8	34,00	4 X M6	12,00	2 x M6
TL-DC-A080-0-A-	80	66,30	32-35	68	25,50	12,00	4,00	8,30	37,00	4 x 5,10	M8	34,00	4 X M6	12,00	3 x M6
TL-DC-A090-0-A-	90	66,00	28	68	25,50	12,00	4,00	7,70	50,00	3 x 6,50	M8	34,00	6 x M6	12,00	3 x M6
TL-DC-A090-0-A-	90	66,00	30-32-35	73	25,50	12,00	4,00	7,70	50,00	3 x 6,50	M8	34,00	6 x M6	12,00	3 x M6
TL-DC-A090-0-A-	90	66,00	38-40	78	25,50	12,00	4,00	7,70	50,00	3 x 6,50	M8	34,00	6 x M6	12,00	3 x M6
TL-DC-A090-0-A-	90	66,00	42-45	83	25,50	12,00	4,00	7,70	50,00	3 x 6,50	M8	34,00	6 x M6	12,00	3 x M6
TL-DC-A090-0-A-	90	66,00	48	88	25,50	12,00	4,00	7,70	50,00	3 x 6,50	M8	34,00	6 x M6	12,00	3 x M6
TL-DC-A100-0-A-	100	66,00	32-35	73	25,50	12,00	4,00	8,00	58,00	3 x 6,50	M8	34,00	6 x M6	12,00	3 x M6
TL-DC-A100-0-A-	100	66,00	38-40	78	25,50	12,00	4,00	8,00	58,00	3 x 6,50	M8	34,00	6 x M6	12,00	3 x M6
TL-DC-A100-0-A-	100	66,00	42-45	83	25,50	12,00	4,00	8,00	58,00	3 x 6,50	M8	34,00	6 x M6	12,00	3 x M6
TL-DC-A100-0-A-	100	66,00	48-50-52	88	25,50	12,00	4,00	8,00	58,00	3 x 6,50	M8	34,00	6 x M6	12,00	3 x M6
TL-DC-A100-0-A-	100	66,00	55	93	25,50	12,00	4,00	8,00	58,00	3 x 6,50	M8	34,00	6 x M6	12,00	3 x M6
TL-DC-A100-0-A-	100	66,00	60	98	25,50	12,00	4,00	8,00	58,00	3 x 6,50	M8	34,00	6 x M6	12,00	3 x M6

\* All measures in mm.

REFERENCE*	MAX TORQUE	MAX SPEED	TORSIONAL RIGIDITY	AXIAL RIGIDITY	WEIGHT
	N.m	rpm	N.m/rad	N/mm	Kg
TL-DC-A070-0-A-	70	18000	60000	105	0,88
TL-DC-A080-0-A-	130	17000	64000	96	1,20
TL-DC-A090-0-A-	200	15000	140000	320	1,57
TL-DC-A100-0-A-	300	13000	160000	360	1,78



## Series DC-A Double

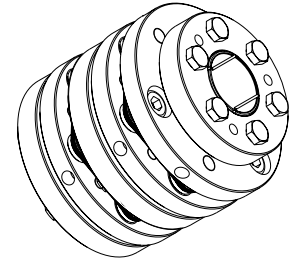
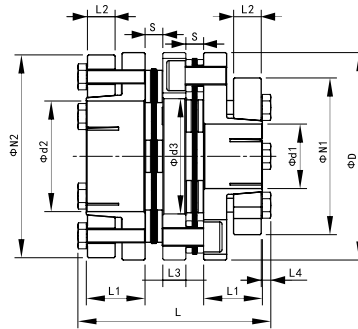
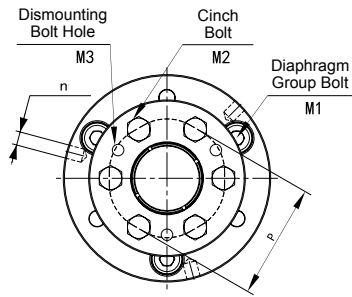

REFERENCE*	D	L	d <sub>1</sub> /d <sub>2</sub>	N <sub>1</sub> /N <sub>2</sub>	L <sub>1</sub>	L <sub>2</sub>	L <sub>3</sub>	D <sub>3</sub>	L <sub>4</sub>	S	P	n	M <sub>1</sub>	LOCKING TORQUE	M <sub>2</sub>	LOCKING TORQUE	M <sub>3</sub>
														N.m		N.m	
TL-DC2-A070-T-A	70	75,00	18-19	53	23,50	12,00	8,00	35	4,00	6,50	31,00	4 x 5,10	M6	14,00	4 x M6	12,00	2 x M6
TL-DC2-A070-T-A	70	75,00	20-22-24-25	58	23,50	12,00	8,00	35	4,00	6,50	31,00	4 x 5,10	M6	14,00	4 x M6	12,00	2 x M6
TL-DC2-A070-T-A	70	75,00	28-30	63	23,50	12,00	8,00	35	4,00	6,50	31,00	4 x 5,10	M6	14,00	4 x M6	12,00	2 x M6
TL-DC2-A070-T-A	70	75,00	32-35	68	23,50	12,00	8,00	35	4,00	6,50	31,00	4 x 5,10	M6	14,00	4 x M6	12,00	2 x M6
TL-DC2-A080-T-A	80	84,60	22-24-25	58	25,50	12,00	10,00	40	4,00	8,30	37,00	4 x 5,10	M8	34,00	4 x M6	12,00	2 x M6
TL-DC2-A080-T-A	80	84,60	28-30-	63	25,50	12,00	10,00	40	4,00	8,30	37,00	4 x 5,10	M8	34,00	4 x M6	12,00	2 x M6
TL-DC2-A080-T-A	80	84,60	32-35-	68	25,50	12,00	10,00	40	4,00	8,30	37,00	4 x 5,10	M8	34,00	4 x M6	12,00	3 x M6
TL-DC2-A090-T-A	90	83,40	28	68	25,50	12,00	10,00	50	4,00	7,70	50,00	3 x 6,50	M8	34,00	6 x M6	12,00	3 x M6
TL-DC2-A090-T-A	90	83,40	30-32-35	73	25,50	12,00	10,00	50	4,00	7,70	50,00	3 x 6,50	M8	34,00	6 x M6	12,00	3 x M6
TL-DC2-A090-T-A	90	83,40	38-40	78	25,50	12,00	10,00	50	4,00	7,70	50,00	3 x 6,50	M8	34,00	6 x M6	12,00	3 x M6
TL-DC2-A090-T-A	90	83,40	42-45	83	25,50	12,00	10,00	50	4,00	7,70	50,00	3 x 6,50	M8	34,00	6 x M6	12,00	3 x M6
TL-DC2-A090-T-A	90	83,40	48	88	25,50	12,00	10,00	50	4,00	7,70	50,00	3 x 6,50	M8	34,00	6 x M6	12,00	3 x M6
TL-DC2-A100-T-A	100	84,00	32-35	73	25,50	12,00	10,00	60	4,00	8,00	58,00	3 x 6,50	M8	34,00	6 x M6	12,00	3 x M6
TL-DC2-A100-T-A	100	84,00	38-40	78	25,50	12,00	10,00	60	4,00	8,00	58,00	3 x 6,50	M8	34,00	6 x M6	12,00	3 x M6
TL-DC2-A100-T-A	100	84,00	42-45	83	25,50	12,00	10,00	60	4,00	8,00	58,00	3 x 6,50	M8	34,00	6 x M6	12,00	3 x M6
TL-DC2-A100-T-A	100	84,00	48-50-52	88	25,50	12,00	10,00	60	4,00	8,00	58,00	3 x 6,50	M8	34,00	6 x M6	12,00	3 x M6
TL-DC2-A100-T-A	100	84,00	55	93	25,50	12,00	10,00	60	4,00	8,00	58,00	3 x 6,50	M8	34,00	6 x M6	12,00	3 x M6
TL-DC2-A100-T-A	100	84,00	60	98	25,50	12,00	10,00	60	4,00	8,00	58,00	3 x 6,50	M8	34,00	6 x M6	12,00	3 x M6

\* All measures in mm.

REFERENCE*	MAX TORQUE	MAX SPEED	TORSIONAL RIGIDITY	AXIAL RIGIDITY	WEIGHT
	N.m	rpm	N.m/rad	N/mm	Kg
TL-DC2-A070-T-A	70	14000	30000	55	1,08
TL-DC2-A080-T-A	130	13000	32000	50	1,54
TL-DC2-A090-T-A	200	12000	70000	160	1,98
TL-DC2-A100-T-A	300	10000	80000	180	2,26



### GUIDE TO ORDER

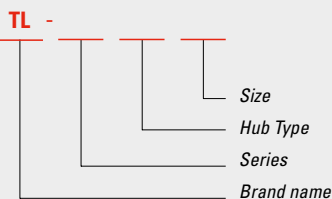

**Size:**  
DC 005 to 100  
DCA 070 to 100

**Hub Type:**  
OA - OB - OC  
Double TA - TB - TC

**Series:**  
DC Single  
DC Double  
DC-A Single  
DC-A Double

**Brand name:**  
TL

## Diaphragm Couplings

With an all-metal construction and no moving parts they look very similar than Disc Couplings. As the torque, transmission is obtained from spring steel wafers contained inside the membrane, which by deforming, accommodate for misalignment. It suits well to high tor-

que and high speed applications, allow for angular, parallel and high axial misalignment. The design provides a nil-backlash and do not require lubrication.

## Tire couplings

Consist of a tire-shaped rubber element that bridges the two hubs of the coupling. The torque is transmitted by shearing the rubber element. This type of coupling absorbs well the shock loads, the vibration, is backlash free and copes with very high misalignments.

Due to the high flexibility of the elastomer, the tyre, the transmission of the torque is backlash free. The tyre is made out of rubber or neoprene with inserted fabric and the set is designed in a way that can be mounted and dismounted radially without the need to assemble-disassemble the set.

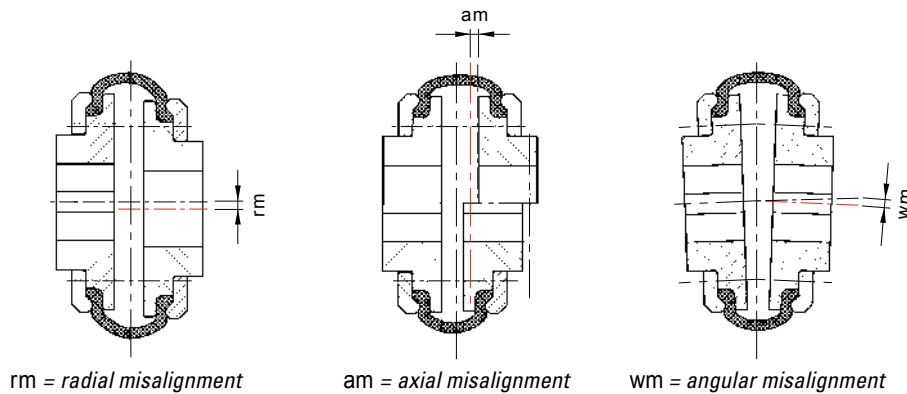

The values of the  $am$ , axial misalignment in the table, are based on an angular misalignment  $wm$  of  $4^\circ$ . This misalignment allowance is based on the fact there is no any radial, nor axial misalignment. The

existence of these other two misalignments will reduce the acceptable angular misalignment. We offer two versions Single and Split:

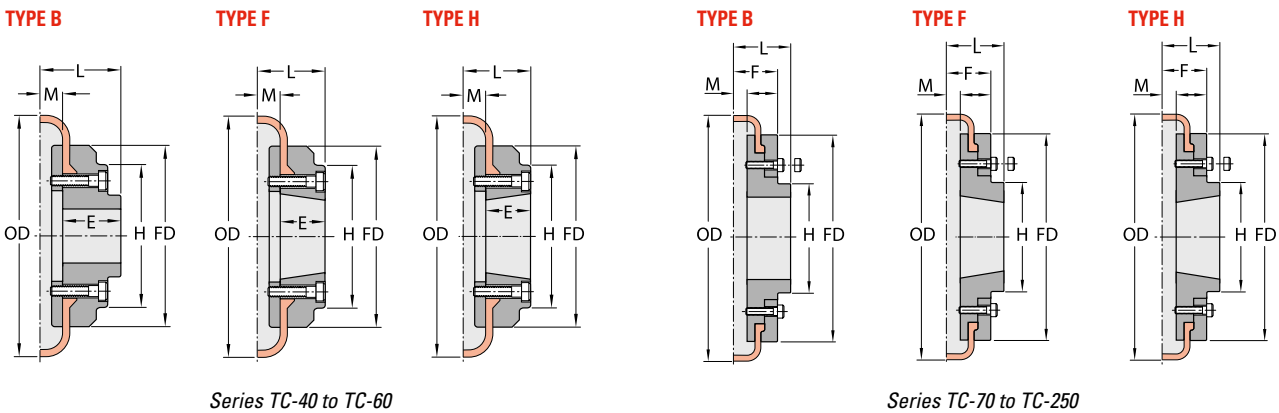

This standard Tire Coupling has two versions related to the way it is fixed to the shafts, either BTS for Bored to Size or the Taper Bush

version, which details are displayed in the table ahead.



Unfitted Coupling



Fitted Elastic tire

There are three flanges available, the types B, F and H, for Bore, Face and Hub respectively and two materials, Casting and Steel. While the B Flange is of BTS type, the F and H are tapered to accommodate

a Taper Bush. These two latter tapered flanges can be Face Mounted or Hub mounted. The B type flanges can be delivered in Metric and Imperial Bores.

## Tire Coupling Sizes

REFERENCE*	FLANGE	TAPER BUSH	BORE MAX mm / inch				L	E	OD	FD	H	F	CASTING	STEEL
			Casting	Steel	Casting	Steel								
TL-TC-40	B		30	1 1/8	30	1 1/8	33,00	22	104	82		11,00	11,00	
TL-TC-40	F	1008	25	1	25	1	33,00	22	104	82		11,00	11,00	
TL-TC-40	H	1008	25	1	25	1	33,00	22	104	82		11,00	11,00	
TL-TC-50	B		38	1 1/2	38	1 1/2	45,00	32	133	100	79	12,50	12,50	
TL-TC-50	F	1210	32	1 1/4	32	1 1/4	38,00	25	133	100	79	12,50	12,50	
TL-TC-50	H	1210	32	1 1/4	32	1 1/4	38,00	25	133	100	79	12,50	12,50	
TL-TC-60	B		42	1 5/8	45	1 3/4	55,00	38	165	125	70	16,50	16,50	
TL-TC-60	F	1610	42	1 5/8	42	1 5/8	42,00	25	165	125	103	16,50	16,50	
TL-TC-60	H	1610	42	1 5/8	42	1 5/8	42,00	25	165	125	103	16,50	16,50	
TL-TC-70	B		48	1 7/8	50	2	47,00	35	187	142	80	50	10,50	11,50
TL-TC-70	F	2012	50	2	50	2	44,00	32	187	142	80	50	10,50	11,50
TL-TC-70	H	1610	42	1 5/8	42	1 5/8	37,00	25	187	142	80	50	10,50	11,50
TL-TC-80	B		55	2 1/4	60	2 3/8	55,00	42	211	165	98	54	12,50	12,50
TL-TC-80	F	2517	60	2 1/2	60	2 1/2	58,00	45	211	165	98	54	12,50	12,50
TL-TC-80	H	2010	50	2	50	2	45,00	32	211	165	98	54	12,50	12,50
TL-TC-90	B		65	2 1/2	75	3	63,50	49	235	188	108	60	13,50	13,50
TL-TC-90	F	2517	60	2 1/2	60	2 1/2	58,50	45	235	188	108	60	13,50	13,50
TL-TC-90	H	2517	60	2 1/2	60	2 1/2	58,50	45	235	188	108	60	13,50	13,50
TL-TC-100	B		80	3 1/8	80	3 1/8	70,50	56	254	216	120	62	13,50	13,50
TL-TC-100	F	3020	75	3	75	3	64,50	51	254	216	125	62	13,50	13,50
TL-TC-100	H	3020	60	2 1/2	60	2 1/2	58,50	45	254	216	113	62	13,50	13,50
TL-TC-110	B		90	3 1/2	90	3 1/2	75,50	63	279	233	128	62	12,50	12,50
TL-TC-110	F	3020	75	3	75	3	63,50	51	279	233	134	62	12,50	12,50
TL-TC-110	H	3020	75	3	75	3	63,50	51	279	233	134	62	12,50	12,50
TL-TC-120	B		95	3 3/4	100	4	84,50	70	314	264	140	67	14,50	14,50
TL-TC-120	F	3525	100	4	100	4	79,50	65	314	264	144	67	14,50	14,50
TL-TC-120	H	3020	75	3	75	3	65,50	51	314	264	144	67	14,50	14,50
TL-TC-140	B		120	4 3/4	125	5	110,50	94	359	311	178	73	16,00	16,00
TL-TC-140	F	3525	100	4	100	4	81,50	65	359	311	178	73	16,00	16,00
TL-TC-140	H	3525	100	4	100	4	81,50	65	359	311	178	73	16,00	16,00
TL-TC-160	B		130	5 1/8	140	5 1/2	117,00	120	402	345	187	78	15,00	15,00
TL-TC-160	F	4030	115	4 1/2	115	4 1/2	92,00	77	402	345	197	78	15,00	15,00
TL-TC-160	H	4030	115	4 1/2	115	4 1/2	92,00	77	402	345	197	78	15,00	15,00
TL-TC-180	B		140	5 1/2	150	6	137,00	114	470	394	205	94	23,00	23,00
TL-TC-180	F	4535	125	5	125	5	112,00	89	470	394	205	94	23,00	23,00
TL-TC-180	H	4535	125	5	125	5	112,00	89	470	394	205	94	23,00	23,00
TL-TC-200	B		140	5 1/2	150	6	138,00	114	508	429	205	103	24,00	24,00
TL-TC-200	F	4535	125	5	125	5	113,00	89	508	429	205	103	24,00	24,00
TL-TC-200	H	4535	125	5	125	5	113,00	89	508	429	205	103	24,00	24,00
TL-TC-220	B		150	6	160	6 1/4	154,50	127	562	474	223	118	27,50	27,50
TL-TC-220	F	5040	125	5	125	5	129,50	102	562	474	223	118	27,50	27,50
TL-TC-220	H	5040	125	5	125	5	129,50	102	562	474	223	118	27,50	27,50
TL-TC-250	B		180	7	190	7 1/2	161,50	132	628	532	254	125	29,50	29,50

\* All measures unless otherwise indicated are expressed in mm. \*\* Taper Bush Bores available in Metric and Imperial. See pages A4 and A5. Taper Bush Keyway according to DIN 6885/1.



Pilot Bore Tire Coupling



QD Tire Coupling



Keyway Tire Coupling



Tire Coupling Element

## Tire Couplings, Torque & Misalignment

REFERENCE	SPEED revs/min	TORQUE* Type N.m			TORSION RIGIDITY N.m/rad	MAX SHAFT MISALIGNMENT. mm		
		Nominal	Maximum	Alternating**		Radial	Axial	Angular***
TL-TC-40	4500	24	64	11	285	1,10	1,30	5,70
TL-TC-50	4500	66	160	26	745	1,30	1,70	7,00
TL-TC-60	4000	127	318	53	1500	1,60	2,00	8,70
TL-TC-70	3600	250	487	41	2350	1,90	2,30	10,00
TL-TC-80	3100	375	759	127	3600	2,10	2,60	12,00
TL-TC-90	3000	500	1096	183	5200	2,40	3,00	13,00
TL-TC-100	2600	675	1517	252	7200	2,60	3,30	15,00
TL-TC-110	2300	875	2137	356	10000	2,90	3,70	16,00
TL-TC-120	2050	1330	3547	591	17000	3,20	4,00	18,00
TL-TC-140	1800	2325	5642	940	28000	3,70	4,60	22,00
TL-TC-160	1600	3770	9339	1556	44500	4,20	5,30	24,00
TL-TC-180	1500	6270	16455	2742	78500	4,80	6,00	28,00
TL-TC-200	1300	9325	23508	3918	110000	5,30	6,60	30,00
TL-TC-220	1100	11600	33125	5521	160000	5,80	7,30	33,00
TL-TC-250	1000	14675	42740	7124	200000	6,60	8,20	37,00

\* Torques understood for keyed shaft.

\*\* Maximum allowed up to a frequency of 10 Hz.

\*\*\* Understood without the coexistence of Radial and Axial misalignments.

## Split Tire Couplings

This Tire Coupling version adds to the characteristics described of the Single Tire Coupling the feature of being split in two halves bolted to reversible hubs.

This feature makes the installation and removal of the coupling very easy.

We offer this coupling in different executions, MPB with Keyway and Taper Bush. Under MTO we can deliver with QD, in Metric and Imperial.

### MPB

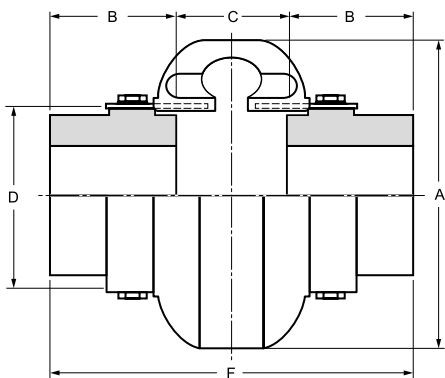

Tire Coupling Split MPB



Tire Coupling Split Keyway

### TAPER BUSH

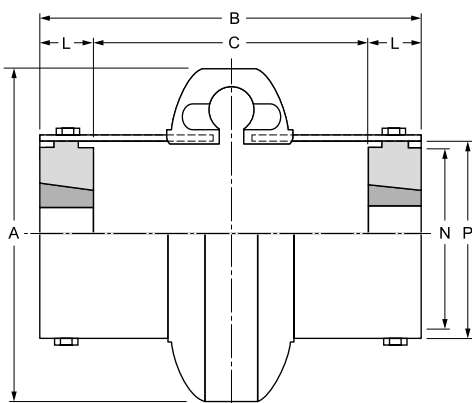

Tire Coupling Split Taper Bush

### Split Tire Couplings. MPB Bores & Keyway version

REFERENCE*	d <sub>1</sub> /d <sub>2</sub>		POWER kW/100	MAXIMUM SPEED	A	B		C		L	N	P
	MINIMUM	MAXIMUM				min	max	min	max			
	Bore. Mm	Bore. Mm										
TL-TC-S2	13	28	0,22	7500	89	84	94	36	456	24	38	47
TL-TC-S3	13	34	0,41	7500	102	84	122	8	46	38	50	59
TL-TC-S4	13	42	0,62	7500	116	84	122	8	46	38	57	66
TL-TC-S5	13	48	1,05	7500	137	97	147	8	59	44	70	80
TL-TC-S10	13	55	1,64	7500	162	97	147	8	59	44	84	93
TL-TC-S20	19	60	2,6	6600	184	113	165	13	65	50	102	114
TL-TC-S30	19	75	4,12	5800	210	125	182	12	69	58	118	138
TL-TC-S40	19	85	6,22	5000	241	135	202	8	75	63	146	168
TL-TC-S50	26	90	8,64	4200	279	151	230	11	91	70	152	207
TL-TC-S60	26	105	14,12	3800	318	173	262	8	97	82	165	222
TL-TC-S70	32	120	24,9	3600	356	189	281	18	109	85	175	235
TL-TC-S80	32	155	44,6	2000	406	245	377	17	149	114	240	286

\* All measures in mm.

### Split Tire Couplings. Taper Bush version

REFERENCE*	TAPER BUSH	d <sub>1</sub> /d <sub>2</sub>		POWER kW/100	MAXIMUM SPEED	A	B	C	N	P
		MAXIMUM	Bore. Mm							
		Number								
TL-TC-S3TB	1008	25	0,41	7500	102	87	43	50	59	
TL-TC-S4TB	1008	25	0,62	7500	116	87	43	57	66	
TL-TC-S5TB	1210	32	1,05	7500	137	102	52	70	80	
TL-TC-S10TB	1610	42	1,64	7500	162	102	52	84	93	
TL-TC-S20TB	1610	42	2,60	6600	184	114	64	102	114	
TL-TC-S30TB	2012	50	4,12	5800	210	129	56	118	138	
TL-TC-S40TB	2517	65	6,22	5000	241	150	60	146	168	
TL-TC-S50TB	2517	65	8,64	4200	279	166	76	152	207	
TL-TC-S60TB	3020	75	14,12	3800	318	186	84	165	222	
TL-TC-S70TB	3535	100	24,90	3600	356	238	60	175	235	
TL-TC-S80TB	4040	110	44,60	2000	406	299	95	204	286	

\* All measures in mm.

### GUIDE TO ORDER

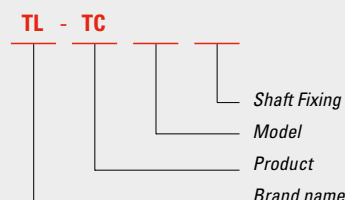

**Shaft Fixing:**  
**MPB** Minimum Plain Bore  
**KW** Keyway  
**TB** Taper Bush  
**QD** Quick Detachable

**Model:**  
 Single Tire 40 through 250  
 Single Tire 52 through 580

**Product:**  
**TC** Tire Coupling

**Brand name:**  
**TL**

## Grid couplings

Consist of a heavy spring that weaves between two radial slotted hubs. The spring steel provides torsional damping and flexibility of an elastomer with the difference of the strength of the steel.

This type of coupling, transmits torque while absorbs angular, parallel

and axial misalignments from the two hubs as well as shock loads.

We offer these couplings in two versions, Horizontal and Vertical. As far as the fixing to the shafts, we have different choices, RSB (Raw Stock Bore), BTS (Bore to Size), KW (Keway).

### Cover Profiles:



Sizes 1020-1140

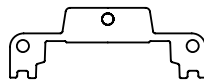

Series 1150 - 1200

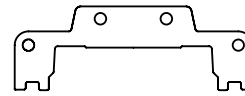

Sizes 1210-1230

### Horizontal Split Cover

REFERENCE*	POWER kW	NOMINAL	MAX SPEED	BORE MM		A	B	C	D	J	F	S	G		LUBRICANT
	x 100 revs/min	Torque N.m	revs/min	min	max								min	max	Oil Kg
TL-GRC-1020	0,54	52	4500	12	30	101,60	98,20	47,50	39,70	66,00		39,10	1,50	4,50	0,027
TL-GRC-1030	1,60	149	4500	12	36	110,00	98,20	47,50	49,20	68,30		39,10	1,50	4,50	0,040
TL-GRC-1040	2,60	249	4500	12	44	117,50	104,60	50,80	57,20	70,00		40,10	1,50	4,50	0,054
TL-GRC-1050	4,60	435	4500	12	50	138,00	123,60	60,30	66,70	79,50		44,70	1,50	4,50	0,068
TL-GRC-1060	7,20	684	4500	19	57	150,50	130,00	63,56	76,20	92,00		52,30	1,50	4,50	0,086
TL-GRC-1070	10,40	994	4125	19	65	161,90	155,40	76,20	87,30	95,00		53,80	1,50	4,50	0,113
TL-GRC-1080	21,50	2050	3600	27	79	194,00	180,80	88,90	104,80	116,00		64,50	1,50	6,00	0,172
TL-GRC-1090	39,00	3730	3600	27	95	213,00	199,80	98,40	123,80	122,00		71,60	1,50	6,00	0,254
TL-GRC-1100	65,70	6280	2440	41	107	250,00	246,20	120,60	142,10	155,50			1,50	9,50	0,426
TL-GRC-1110	97,60	9320	2250	41	117	270,00	259,00	127,00	160,30	161,50			1,50	9,50	0,508
TL-GRC-1120	143,00	13700	2025	60	136	308,00	304,40	149,20	179,40	191,50			1,50	12,50	0,735
TL-GRC-1130	208,00	19900	1800	66	165	346,00	329,80	161,90	217,50	195,00			1,50	12,50	0,907
TL-GRC-1140	299,00	28600	1650	66	184	384,00	374,40	184,20	254,00	201,00			1,50	12,50	1,130
TL-GRC-1150	416,00	39800	1500	108	203	453,10	371,80	182,90	269,20	271,30	391,20		1,50	12,50	1,950
TL-GRC-1160	586,00	55900	1350	120	228	501,40	402,20	198,10	304,80	278,90	436,90		1,50	12,50	2,810
TL-GRC-1170	781,00	74600	1225	133	279	566,40	437,80	215,96	355,60	304,30	487,20		1,50	12,50	3,490
TL-GRC-1180	1080,00	103000	1100	152	311	629,9	483,6	238,8	393,7	321,1	554,7		1,50	12,50	3,760
TL-GRC-1190	1430,00	137000	1050	152	339	675,6	524,2	259,1	436,9	325,1	607,8		1,50	12,50	4,400
TL-GRC-1200	1950,00	186000	900	177	361	756,9	564,8	279,4	497,8	355,6	660,4		1,50	12,50	5,620
TL-GRC-1210	2611,00	249000	820	177	390	844,5	622,3	304,8	533,4	431,8	750,8		1,50	12,70	10,500
TL-GRC-1220	3523,00	336000	730	203	420	920,7	662,9	325,1	571,5	490,2	822,2		1,50	12,70	16,100

\* All measures in mm unless otherwise indicated.

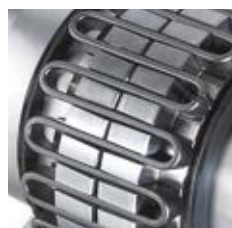

Spring detail

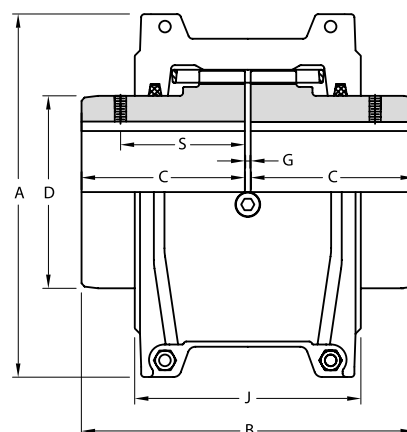

## Vertical Split Cover

REFERENCE*	POWER kW	NOMINAL	MAX SPEED	BORE MM		A	B	C	D	F	H	J	M	S	G		LUBRICANT
	x 100 revs/min	Torque N.m	revs/min	min	max											min	max
TL-GRC-A1020	0,54	52	6000	12	30	111,10	98,00	47,50	39,70	64,30	9,70	24,20	47,80	39,10	1,50	4,50	0,027
TL-GRC-A1030	1,60	149	6000	12	36	120,70	98,00	47,05	49,20	73,80	9,70	25,00	47,80	39,10	1,50	4,50	0,040
TL-GRC-A1040	2,60	249	6000	12	44	128,50	104,60	50,80	57,20	81,38	9,70	25,70	50,80	40,10	1,50	4,50	0,054
TL-GRC-A1050	4,60	435	6000	12	50	147,60	123,60	60,30	66,70	97,60	11,90	31,20	60,50	44,70	1,50	4,50	0,068
TL-GRC-A1060	7,20	684	6000	19	57	162,00	130,00	63,50	76,20	111,10	12,70	32,20	63,50	52,30	1,50	4,50	0,086
TL-GRC-A1070	10,40	994	5500	19	65	173,00	155,40	76,20	87,30	122,30	12,70	33,70	66,50	53,80	1,50	4,50	0,113
TL-GRC-A1080	21,50	2050	4750	27	79	200,00	180,80	88,90	104,80	149,20	12,70	44,20	88,90	64,50	1,50	6,00	0,172
TL-GRC-A1090	39,00	3730	4000	27	95	231,80	199,80	98,40	123,80	168,30	12,70	47,70	95,20	71,60	1,50	6,00	0,254
TL-GRC-A1100	65,70	6280	3250	41	107	266,70	245,70	120,60	142,10	198,00	15,70	60,00	120,70		1,50	9,50	0,426
TL-GRC-A1110	97,60	9320	3000	41	117	285,80	258,50	127,00	160,30	216,30	16,00	64,20	124,00		1,50	9,50	0,508
TL-GRC-A1120	143,00	13700	2700	60	136	319,00	304,40	149,20	179,40	245,50	17,50	73,40	142,70		1,50	12,50	0,735
TL-GRC-A1130	208,00	19900	2400	66	165	377,80	329,80	161,90	217,50	283,80	20,60	75,10	146,00		1,50	12,50	0,907
TL-GRC-A1140	299,00	28600	2200	66	184	416,00	371,60	184,20	254,00	321,90	20,60	78,20	155,40		1,50	12,50	1,130
TL-GRC-A1150	416,00	39800	2000	108	203	476,30	371,80	182,90	269,20	374,40	19,30	106,90	203,20		1,50	12,50	10,950
TL-GRC-A1160	586,00	55900	1750	120	228	533,40	402,20	198,10	304,80	423,90	30,00	114,30	215,90		1,50	12,50	2,810
TL-GRC-A1170	781,00	74600	1600	133	279	584,20	437,80	215,90	355,60	474,70	30,00	119,40	226,10		1,50	12,50	3,490
TL-GRC-A1180	1080,00	103000	1400	152	311	630,00	483,60	238,80	393,70			130,00	265,00		1,50	12,50	3,760
TL-GRC-A1190	1430,00	137000	1300	152	339	685,00	524,20	259,10	436,90			135,00	275,00		1,50	12,50	4,400
TL-GRC-A1200	1950,00	186000	1100	177	361	737,00	564,80	279,40	497,80			145,00	295,00		1,50	12,50	5,620

\* All measures in mm unless otherwise indicated.



Grid

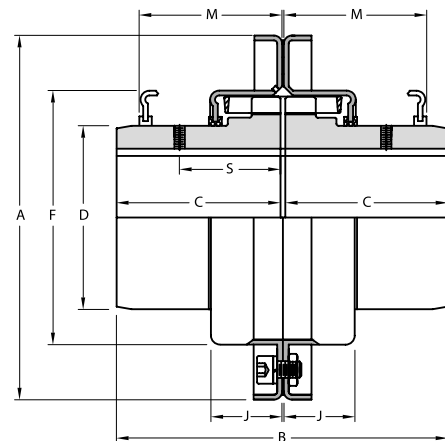

## Service Factors

At the time of selecting the model to fit the appropriate application, the Service Factors are to be taken much into account. These vary according to the type of load of the driven shaft demands. As a guide, Service factors vary from 1 for constant uniform torque, 1,5 for some torque variations, 2 for light shock loads, 2,5 for moderate shock loads and 3 for heavy shock loads.



Grid Hub MPB

## GUIDE TO ORDER

**TL - GC**

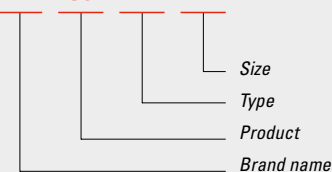

Size:  
1020 through 1220

Type:  
H Horizontal  
V Vertical

Product:  
GC Grid Coupling

Brand name:  
TL



## Oldham<sup>1</sup> couplings

Consists of two identical metal elements with slots that sandwich a slider block between them. This type of couplings are well suited for shaft's parallel misalignment but they are less effective in compensating the angular misalignments. The slider block is usually made out of a polymer. By pressing the metal slotted elements, the backlash is minimized but in revenge, the friction developed makes the sliding block to wear and ultimately the backlash appears. The metal elements are attached to the shafts either by the pair keyway-key or a friction locking device.

Indicated for stepper-motor driven angular positioning, in robotics, in printers and in general in applications with pronounced parallel misalignments.

**Nomenclature:** We identify this type of Jaw Coupling by OC with four versions all of them of Aluminum, OC-A for One-piece Set Screw with PA66\* Polyamide Sliding Block (Nylon), OC-B as OC-A with a Bronze Sliding Block, OC-C for Two-piece Clamp Type with Nylon Sliding Block and OC-D as OC-C with Bronze Sliding Block.

### One piece type A. SetScrew

REFERENCE*	OD	L	BORES $d_1/d_2$	$L_f$	$L_p$	F	M
TL-OC-A16	16	18	4 to 6,35	7,25	11,60	3,35	4 M3 x 5
TL-OC-A20	20	23	6 to 10	9,15	12,70	5,51	4 M3 x 5
TL-OC-A25	25	28	6,35 to 12	11,50	16,60	5,70	4 M4 x 6
TL-OC-A32	32	33	8 to 16	13,75	19,50	6,75	4 M5 x 8
TL-OC-A40	40	35	8 to 18	15,10	18,40	8,30	4 M6 x 12
TL-OC-A50	50	38	10 to 22	19,00	15,00	5,75	4 M6 x 12
TL-OC-A55	55	57	10 to 22	28,00	20,00	9,25	4 M8 x 14
TL-OC-A63	63	47	15 to 25	22,75	17,50	7,38	4 M8 x 14
TL-OC-A70	70	57	19 to 35	27,50	19,00	9,50	4 M8 x 16

\* All measures in mm unless otherwise indicated.

### Technical Specifications

REFERENCE*	RATED	MAX	MISALIGNMENT ALLOWANCE			MAX SPEED	STIFFNESS	WEIGHT
	Torque N.m	Torque N.m	Axial $\mu\text{m}$ +	Radial $\mu\text{m}$	Angular $\text{wm}^\circ$	revs/min	N.m/rad	Gramm
TL-OC-A16	0,70	1,40	0,20	0,80	3	10000	30	6
TL-OC-A20	1,20	2,40	0,20	1,00	3	10000	58	15
TL-OC-A25	2,00	4,00	0,20	1,20	3	10000	130	25
TL-OC-A32	4,50	9,00	0,20	1,50	3	9000	270	44
TL-OC-A40	9,00	1,80	0,20	1,80	3	7500	520	81
TL-OC-A50	19,00	38,00	0,20	2,00	3	7000	800	142
TL-OC-A55	25,00	50,00	0,20	2,00	3	6700	900	280
TL-OC-A63	33,00	68,00	0,20	2,00	3	6300	1200	320
TL-OC-A70	36,00	72,00	0,20	2,00	3	6000	4800	430

\* All measures in mm unless otherwise mentioned.

Sliding block element of Polyamide PA66.

Material, Anodized High Strength Aluminum.

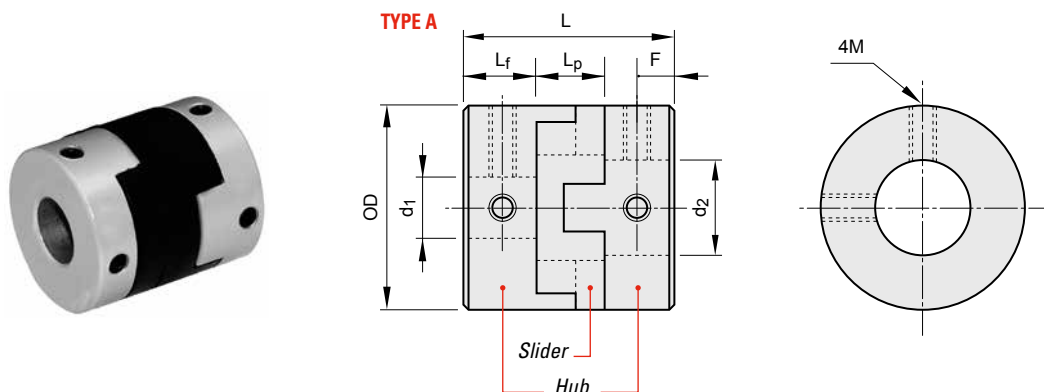

<sup>1</sup> After John Oldham (1779-1840) the Irish engineer inventor.

### One piece type B. Set Screw

REFERENCE*	OD	L	BORES $d_1/d_2$	$L_f$	$L_1$	$L_2$	$L_p$	F	M
TL-OC-B15	15	16	4 to 6,35	7,80	5,20	2,60	5,60	2,50	4 M3 x 4
TL-OC-B17	17	20	5 to 8	9,80	6,70	3,30	6,60	3,25	4 M4 x 4
TL-OC-B20	20	23	6 to 10	11,30	8,00	3,30	7,00	4,00	4 M4 x 5
TL-OC-B26	26	26	6 to 12,7	14,30	9,00	5,30	8,00	4,50	4 M4 x 6
TL-OC-B30	30	33	8 to 14	16,20	10,50	5,70	12,00	5,52	4 M4 x 8
TL-OC-B34	34	35	10 to 15	17,20	11,50	5,70	12,00	5,75	4 M5 x 10
TL-OC-B38	38	40	10 to 20	19,70	13,00	6,70	14,00	6,50	4 M5 x 10
TL-OC-B44	44	46	12 to 22	22,00	14,00	8,00	18,00	7,50	4 M6 x 12
TL-OC-B55	55	50	14 to 28	24,50	17,00	7,50	16,00	8,50	4 M8 x 14
TL-OC-B70	70	57	19 to 35	27,50	19,00	8,50	19,00	9,50	4 M10 x 16

\* All measures in mm unless otherwise indicated.

### Technical Specifications

REFERENCE*	RATED	MAX	MISALIGNMENT ALLOWANCE			MAX SPEED	STIFFNESS	WEIGHT
	Torque N.m	Torque N.m	Axial $\mu\text{m}$ +	Radial $\mu\text{m}$	Angular $\text{wm}^\circ$	revs/min	N.m/rad	Gramm
TL-OC-B15	3,00	6,00	0,10	0,50	1,5	5000	860	15
TL-OC-B17	5,00	10,00	0,10	0,50	1,5	4000	1200	25
TL-OC-B20	7,00	14,00	0,10	0,60	1,5	4000	1600	37
TL-OC-B26	10,00	20,00	0,10	0,80	1,5	3800	3200	79
TL-OC-B30	30,00	60,00	0,10	1,00	1,5	3500	4500	120
TL-OC-B34	34,00	68,00	0,10	1,00	1,5	3200	6000	180
TL-OC-B38	40,00	80,00	0,10	1,00	1,5	3000	7200	255
TL-OC-B44	50,00	100,00	0,10	1,00	1,5	2500	15000	365
TL-OC-B55	80,00	160,00	0,10	1,00	1,5	2000	29000	620
TL-OC-B70	160,00	320,00	0,10	1,00	1,5	2000	45000	1050

\* All measures in mm unless otherwise mentioned.  
Sliding block element of Aluminum Bronze.  
Material, Stainless Steel 316F.

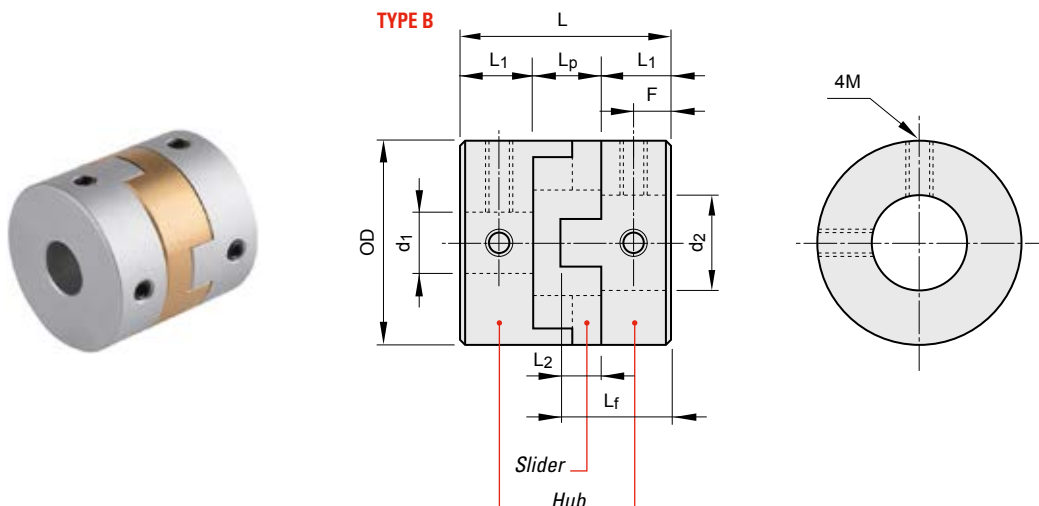

## Clamping type

REFERENCE*	OD	L	BORES $d_1/d_2$	$L_f$	$L_1$	$L_2$	$L_p$	F	M
TL-OC-C16	16	22	4 to 6,35	10,80	3,00	3,30	7,00	3,40	2 M2.5 x 8
TL-OC-C16	16	30	4 to 6,35	13,20	3,90	3,90	11,30	3,40	2 M2.5 x 8
TL-OC-C20	20	28	5 to 8	13,80	3,50	3,30	7,00	4,00	2 M2.5 x 10
TL-OC-C20	20	33	5 to 10	14,10	4,00	4,00	12,70	3,50	2 M2.5 x 10
TL-OC-C25	25	28	6 to 11	13,70	5,00	5,00	10,00	3,90	2 M3 x 12
TL-OC-C25	25	39	6 to 11	17,00	6,20	5,80	16,60	4,00	2 M3 x 12
TL-OC-C32	32	35	8 to 14	17,20	6,00	5,70	12,00	4,75	2 M4 x 14
TL-OC-C32	32	45	8 to 14	19,80	7,20	7,00	19,50	4,80	2 M4 x 14
TL-OC-C40	40	50	8 to 19	22,60	7,20	6,80	18,40	5,60	2 M5 x 16
TL-OC-C44	44	46	10 to 22	22,00	7,00	8,00	18,00	6,00	2 M5 x 16
TL-OC-C50	50	58	10 to 22	28,50	9,00	9,50	20,00	7,50	2 M6 x 25
TL-OC-C63	63	71	15 to 32	37,00	9,00	13,50	24,00	9,00	2 M8 x 25
TL-OC-C70	70	77	19 to 35	41,50	16,50	16,50	27,00	9,00	2 M8 x 30

\* All measures in mm unless otherwise indicated.

## Technical Specifications

REFERENCE*	RATED	MAX	MISALIGNMENT ALLOWANCE			MAX SPEED	STIFFNESS	WEIGHT
	Torque N.m	Torque N.m	Axial $\mu\text{m}$	Radial $\mu\text{m}$	Angular $\text{wm}^\circ$	revs/min	N.m/rad	Gramm
TL-OC-C16	0,70	1,40	0,20	0,80	3	10000	30	9
TL-OC-C16	0,70	1,40	0,20	0,80	3	10000	30	12
TL-OC-C20	1,00	2,00	0,20	1,00	3	10000	45	16
TL-OC-C20	1,20	2,40	0,20	1,20	3	10000	58	19
TL-OC-C25	1,50	3,00	0,20	1,20	3	10000	120	32
TL-OC-C25	2,00	4,00	0,20	1,50	3	10000	130	35
TL-OC-C32	3,50	7,00	0,20	1,50	3	9000	250	47
TL-OC-C32	4,50	9,00	0,20	1,80	3	8000	270	67
TL-OC-C40	9,00	16,00	0,20	2,00	3	7500	520	114
TL-OC-C44	12,00	24,00	0,20	2,00	3	7500	560	136
TL-OC-C50	19,00	38,00	0,20	2,00	3	7000	800	215
TL-OC-C63	33,00	66,00	0,20	2,00	3	6300	1200	465
TL-OC-C70	36,00	72,00	0,20	2,00	3	6000	4800	490

\* All measures in mm unless otherwise mentioned.

Sliding block element of Polyamide PA66.

Material, Anodized High Strength Aluminum.

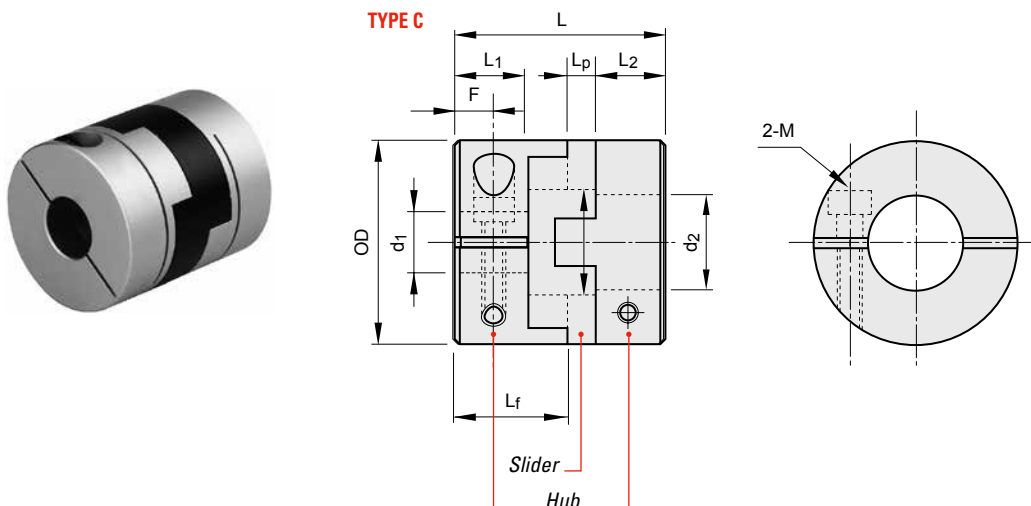

## Clamping type

REFERENCE*	OD	L	BORES $d_1/d_2$	$L_f$	$L_1$	$L_2$	$L_p$	F	M
TL-OC-D16	16,00	22,00	3 to 6	10,80	7,50	3,30	3,30	3,40	2 M2,5
TL-OC-D20	20,00	28,00	5 to 8	13,80	10,50	3,30	3,30	4,00	2 M3
TL-OC-D26	26,00	30,00	5 to 12	14,70	9,50	5,20	5,20	3,90	2 M3
TL-OC-D30	30,00	35,00	5 to 14	17,20	11,50	5,70	5,70	4,75	2 M4
TL-OC-D32	32,00	35,00	5 to 14	17,20	11,50	5,70	5,70	4,75	2 M4
TL-OC-D34	34,00	35,00	5 to 16	17,20	11,50	5,70	5,70	4,75	2 M4
TL-OC-D38	38,00	40,00	8 to 19	19,70	13,00	5,70	5,70	5,25	2 M4
TL-OC-D44	44,00	46,00	8 to 22	22,00	14,00	8,00	8,00	6,00	2 M5
TL-OC-D55	54,50	53,00	12 to 28	26,00	16,50	9,50	9,50	7,50	2 M6
TL-OC-D55	54,50	58,00	12 to 28	28,50	19,00	9,50	9,50	7,50	2 M6
TL-OC-D63	63,00	71,00	14 to 32	37,00	23,50	13,50	13,50	9,00	2 M8
TL-OC-D70	69,50	77,00	14 to 35	41,50	25,00	16,50	16,50	9,00	3 M8

\* All measures in mm unless otherwise indicated.

## Technical Specifications

REFERENCE*	RATED	MAX	MISALIGNMENT ALLOWANCE			MAX SPEED	STIFFNESS	WEIGHT
	Torque N.m	Torque N.m	Axial $\mu\text{m}$ +	Radial $\mu\text{m}$	Angular $\text{wm}^\circ$	revs/min	N.m/rad	Gramm
TL-OC-D16	4,00	8,00	0,10	0,50	1,5	4500	1100	28
TL-OC-D20	7,00	14,00	0,10	0,60	1,5	4000	1600	47
TL-OC-D26	10,00	20,00	0,10	0,80	1,5	3800	3200	85
TL-OC-D30	30,00	60,00	0,10	1,00	1,5	3500	4500	135
TL-OC-D32	32,00	64,00	0,10	1,00	1,5	3300	5000	150
TL-OC-D34	34,00	68,00	0,10	1,00	1,5	3200	6000	173
TL-OC-D38	40,00	80,00	0,10	1,00	1,5	3000	7200	235
TL-OC-D44	50,00	100,00	0,10	1,00	1,5	2500	15000	370
TL-OC-D55	70,00	140,00	0,10	1,00	2,5	2000	29000	720
TL-OC-D55	80,00	160,00	0,10	1,00	3,5	2000	29000	750
TL-OC-D63	120,00	240,00	0,10	1,00	4,5	2000	41000	1213
TL-OC-D70	160,00	320,00	0,10	1,00	5,5	2000	45000	1360

\* All measures in mm unless otherwise mentioned.  
Sliding block element of Aluminum Bronze.  
Material, Stainless Steel 316F.

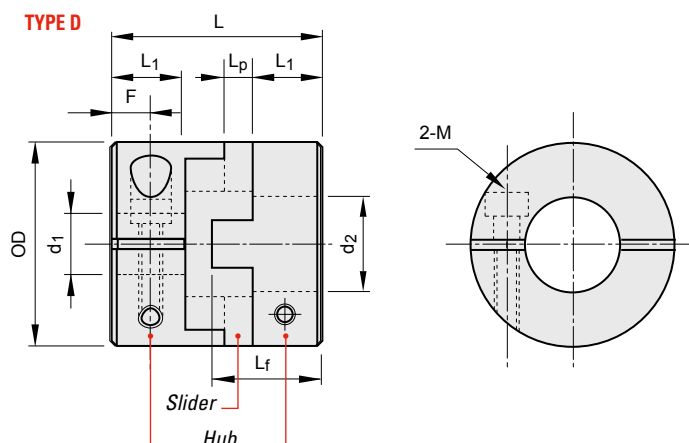

## GUIDE TO ORDER

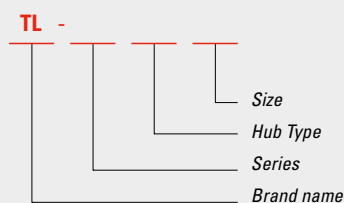

Size:  
DC 005 to 100  
DCA 070 to 100

Hub Type:  
OA - OB - OC  
Double TA - TB - TC

Series:  
DC Single  
DC Double  
DC-A Single  
DC-A Double

Brand name:  
TL

## Pin Bush Couplings

Consist of two hub sections connected by steel pins and elastomer buffers. They are able to transmit high torque at high speeds while the elastomers compensate for the misalignments produced by either the shaft's load or temperature variations. They can operate at environment temperatures from -20°C to +70°C, they require only a little maintenance, the buffer elastomers are the only wearing parts and they are suitable for horizontal and vertical applications.

The elastomer and pins are mounted on one side and on bigger models can be delivered with elastomers mounted on the hubs on alternate sides.

**Materials:** Hubs made of Cast Iron and elastomers are of NBR Shore A65, Shore A80 or Shore A90.

The Hubs are connected to the driving shaft by keyway. The torque is transmitted through the elastomers to the Hub onto the driven shaft side connected by keyway as well. We supply them with Pilot Bore (MPB), Bored to Size (BTS) or Keyway.

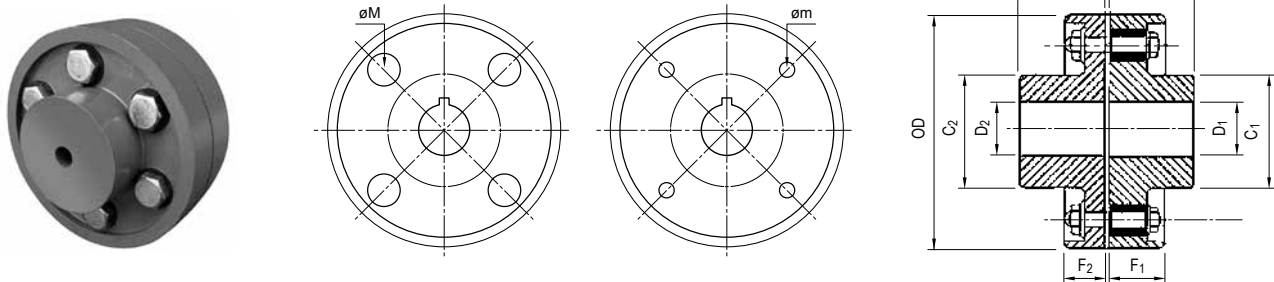

REFERENCE*	OD	L	MAX D <sub>1</sub> /D <sub>2</sub>	C <sub>1</sub>	C <sub>2</sub>	F <sub>1</sub>	F <sub>2</sub>	n	DIA		s	BOLT SIZE	ELEMENT TYPE
									m	M			
TL-PB-76	76	27,00	15	33,50	33,50	11,00	11,00	3	8,00	18,00	3	M8 x 46	F0
TL-PB-90	90	28,00	20	35,50	35,50	14,00	14,00	4	8,00	19,00	3	M8 x 50	F1
TL-PB-100	100	35,50	25	42,50	42,50	16,00	16,00	4	10,00	23,00	3	M10 x 56	F2
TL-PB-112	112	40,00	28	50,00	50,00	16,00	16,00	4	10,00	23,00	3	M10 x 56	F2
TL-PB-125	125	45,00	32	56,00	50,00	18,00	18,00	4	14,00	32,00	3	M12 x 64	F3
TL-PB-130	130	45,00	32	61,00	55,00	18,00	18,00	4	14,00	32,00	3	M12 x 64	F3
TL-PB-140	140	50,00	38	71,00	63,00	18,00	18,00	6	14,00	32,00	3	M12 x 64	F3
TL-PB-150	150	55,00	40	75,00	70,00	18,00	18,00	8	14,00	32,00	3	M12 x 64	F3
TL-PB-160	160	56,00	45	80,00	80,00	18,00	18,00	8	14,00	32,00	3	M12 x 64	F3
TL-PB-165	165	60,00	45	83,00	83,00	18,00	18,00	8	14,00	32,00	3	M12 x 64	F3
TL-PB-180	180	63,00	50	90,00	90,00	18,00	18,00	8	14,00	32,00	3	M12 x 64	F3
TL-PB-200	200	71,00	56	100,00	100,00	22,40	22,40	8	20,00	41,00	4	M20 x 85	F4
TL-PB-224	224	80,00	63	112,00	112,00	22,40	22,40	8	20,00	41,00	4	M20 x 85	F4
TL-PB-235	235	85,00	65	117,00	117,00	22,40	22,40	8	20,00	41,00	4	M20 x 85	F4
TL-PB-250	250	90,00	71	125,00	125,00	28,00	28,00	8	25,00	51,00	4	M24 x 100	F5
TL-PB-280	280	100,00	80	140,00	140,00	28,00	40,00	8	25,00	57,00	4	M24 x 116	F6
TL-PB-300	300	110,00	85	155,00	155,00	28,00	40,00	8	28,00	57,00	4	M24 x 116	F6
TL-PB-315	315	112,00	90	160,00	160,00	28,00	40,00	10	28,00	57,00	4	M24 x 116	F6
TL-PB-355	355	125,00	100	180,00	180,00	35,50	56,00	8	28,00	72,00	5	M30 x 150	F7
TL-PB-380	380	125,00	105	190,00	190,00	35,50	56,00	10	35,50	72,00	5	M30 x 150	F7
TL-PB-400	400	125,00	110	200,00	200,00	35,50	56,00	10	35,50	72,00	5	M30 x 150	F7
TL-PB-420	420	130,00	115	210,00	210,00	35,50	56,00	10	35,50	72,00	5	M30 x 150	F7
TL-PB-430	430	132,00	120	213,00	213,00	35,50	56,00	12	35,50	72,00	5	M30 x 150	F7
TL-PB-450	450	140,00	125	224,00	224,00	35,50	56,00	12	35,50	72,00	5	M30 x 150	F7

\* All measures in mm unless otherwise mentioned.

Supplied MPB, BTS or Keyway.

GG25 Cast Iron Hubs.

C45 Steel Bolts and Nuts.



### Service Factors Guide

LOAD TORQUE	PRIME MOVER			
	ELECTRIC MOTOR	WATER TURBINE	RECIPROCATING ENGINES	
TYPE			> pistons	< pistons
LD Light Duty	1	1,25	1,5	2
MD Medium Duty	1,75	2	2,25	3
HD Heavy Duty	2,25	2,5	2,75	3,5



Yellow zinc plated  
Elastomer Buffer Pin with Grower  
and Nut

### GUIDE TO ORDER

**TL - PB**

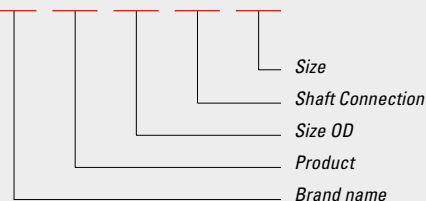

Size of Shaft  
connection

Shaft connection:

**MPB**  
**BTS**  
**Keyway**

Size OD:  
76 through 450

Product:  
PB Pin Bush Coupling

Brand name:  
**TL**

### Mechanical Flexing Couplings

As described these types operate with mechanisms between shafts,

from which they attain their flexibility.

### Chain Couplings

Consist of two symmetric hub-sprockets connected together with a double strand roller chain. The result is a very simple and compact coupling set. The torque is transmitted by the roller chain and is distributed throughout the whole of it. This type of coupling absorbs vibrations and pulsating loads. For this type of loads it is recommended using one size above than the technical data prescribes.

This type of couplings are mainly used in low to moderate speed.

A cover case is available, protecting the coupling on one side and as a grease reservoir for the roller chain.

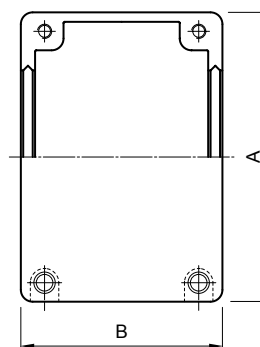
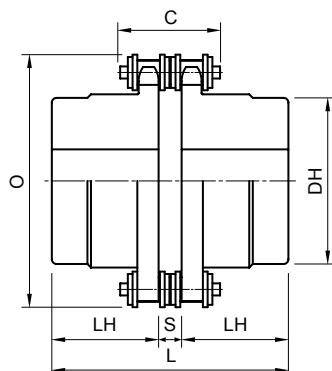

## Chain Couplings Sizes

REFERENCE**	CHAIN PITCH	COUPLING										COUPLING CASE		
		PILOT BORE BORE	BORE MM		O	L	DH	LH	S	C	APROX. WEIGHT KG	A	B	APROX. WEIGHT KG
			min	max										
TL-CC-3012	9,525	12,00	13,50	16	45	65,00	27,20	29,5	6,00	10,10	0,31	69	63	0,22 €
TL-CC-4012	12,700	12,00	14,00	22	62	79,40	36,00	36	7,40	14,40	0,73	77	72	0,30 €
TL-CC-4014	12,700	12,00	14,00	28	69	79,40	45,00	36	7,40	14,40	1,12	84	75	0,31 €
TL-CC-4016	12,700	13,50	16,00	32	77	87,40	51,50	40	7,40	14,40	1,50	92	72	0,35 €
TL-CC-5014	15,875	14,50	17,00	35	86	99,70	56,00	45	9,70	18,10	2,15	101	85	0,47 €
TL-CC-5016	15,875	14,50	18,00	40	96	99,70	64,00	45	9,70	18,10	2,75	110	87	5,00 €
TL-CC-5018	15,875	16,00	18,00	45	106	99,70	7,35	45	9,70	18,10	3,60	122	85	0,60 €
TL-CC-6018	19,050	20,00	22,00	56	127	123,50	89,50	56	11,50	22,80	6,55	147	105	1,20 €
TL-CC-6020	19,050	20,00	24,00	60	139	123,50	102,50	56	11,50	22,80	8,38	158	105	1,20 €
TL-CC-6022	19,050	20,00	28,00	71	151	123,50	115,00	56	11,50	22,80	10,40	168	117	1,20 €
TL-CC-8018	20,400	20,00	32,00	80	169	141,20	115,00	63	15,20	29,30	13,20	190	129	1,90 €
TL-CC-8020	20,400	20,00	36,00	90	185	145,20	125,00	65	15,20	29,30	16,20	210	137	2,50 €
TL-CC-8022	20,400	20,00	40,00	100	202	157,20	142,00	71	15,20	29,30	21,80	226	137	2,70 €
TL-CC-10020	31,750	25,00	45,00	110	233	178,80	162,00	80	18,80	35,80	32,40	281	153	4,10 €
TL-CC-12018	38,100	35,00	50,00	125	256	202,70	173,00	90	22,70	45,40	43,20	307	181	5,20 €
TL-CC-12022	38,100	35,00	56,00	140	304	222,70	213,00	100	22,70	45,40	69,10	357	181	6,70 €

Offered with Pilot Bore as Standard, BTS or Keyway. Delivery under MTO with QD Type Bush.

\*\* All measures in mm unless otherwise indicated.



Chain Coupling Assembly



Chain Coupling Keyway



Chain Coupling Pilot Bore

## Power Ratings, kW

SPEED REVS/MIN	COUPLING TL-CC-													
	3012	4012	4014	4016	5014	5016	5018	6018	6022	8018	8022	10020	12018	12022
1	0,01	0,02	0,03	0,04	0,06	0,08	0,10	0,18	0,25	0,41	0,59	0,93	1,40	1,81
5	0,05	0,11	0,16	0,21	0,30	0,39	0,50	0,93	1,25	2,07	2,96	4,66	7,02	9,07
10	0,11	0,22	0,32	0,41	0,60	0,78	0,99	1,87	2,51	4,14	5,93	9,33	14,00	1,81
25	0,26	0,58	0,79	1,03	1,50	1,95	2,48	4,67	6,31	10,30	14,80	23,30	35,10	45,30
50	0,52	1,15	1,58	2,06	3,00	3,91	4,95	9,33	12,50	20,70	29,60	46,60	70,20	90,70
100	0,79	1,73	2,36	3,09	4,48	5,86	7,43	14,00	18,80	31,00	44,50	70,00	105,00	136,00
200	1,21	2,63	3,59	4,69	6,80	8,92	11,30	21,30	28,60	47,20	67,20	106,00	160,00	206,00
300	1,58	3,46	4,72	6,17	8,95	11,70	14,90	28,00	37,70	62,10	89,00	140,00	210,00	272,00
400	1,89	4,15	5,66	7,41	10,70	14,10	17,80	33,60	45,30	74,50	106,00	168,00	252,00	326,00
500	2,26	4,96	6,77	8,85	12,80	16,80	21,30	40,10	54,10	89,00	127,00	200,00	302,00	390,00
600	2,58	5,67	7,72	10,10	14,70	19,20	24,40	45,90	61,90	101,00	146,00	229,00	345,00	446,00
800	3,19	7,01	9,56	12,50	18,10	23,80	30,10	56,80	76,50	126,00	180,00	283,00	426,00	551,00
1000	3,88	8,53	11,60	15,30	22,10	28,90	36,60	69,10	93,10	153,00	219,00	345,00	519,00	671,00
1200	4,41	9,68	13,20	17,30	25,10	32,90	41,60	78,40	105,00	174,00	249,00	392,00	590,00	762,00
1500	5,35	11,60	15,80	21,00	30,00	39,90	50,50	95,20	128,00	211,00	302,00	476,00	716,00	

NEXT >



**Power Ratings, kW**

SPEED REVS./MIN	COUPLING TL-CC-													
	3012	4012	4014	4016	5014	5016	5018	6018	6022	8018	8022	10020	12018	12022
1800	6,25	13,70	18,70	24,40	35,40	46,40	58,80	111,00	149,00	246,00	352,00	554,00		
2500	6,73	14,80	20,20	26,30	38,30	50,00	63,40	120,00	161,00	265,00	379,00			
2800	8,12	17,90	24,40	31,90	46,20	60,60	76,80	145,00	195,00					
3000	9,44	20,70	28,30	37,00	53,60	70,40	89,20							
3600	11,00	24,10	32,90	43,00	62,40	81,60								
4000	12,00	26,30	35,90	46,90										
4800	14,00	30,80	42,10	54,90										
5200	14,80													
6000	16,70													

**Gear couplings**

Consist of two hubs with external crown gears, which mesh with internal gear of flanged sleeves, bolted together. This type of couplings absorb angular and axial misalignments, the former by the rocking of the crown gear and the latter by the sliding against the sleeve teeth. They transmit the highest torque in the smallest diameter.

Our Series GC is a combination of a Sleeve and Gear Coupling where an inside-gearred nylon and the outside-gearred steel hubs mesh. The external hub teeth is designed according the curved tooth principle resulting to a minimum edge pressure in the spline.

The splined sleeve is made out of nylon, which provides smoothness, hardness, flexibility, sliding ease, no embrittlement at low temperature, high mechanical properties, high resistance to chemical agents, high electrical insulation and high stiffness.

The combination of the nylon sleeve and the steel-curved-tooth hubs make their meshing action to be practically free of wear. In this type of coupling the double-cardanic action counterbalance the axial, parallel and angular misalignments at the time its transmits power.

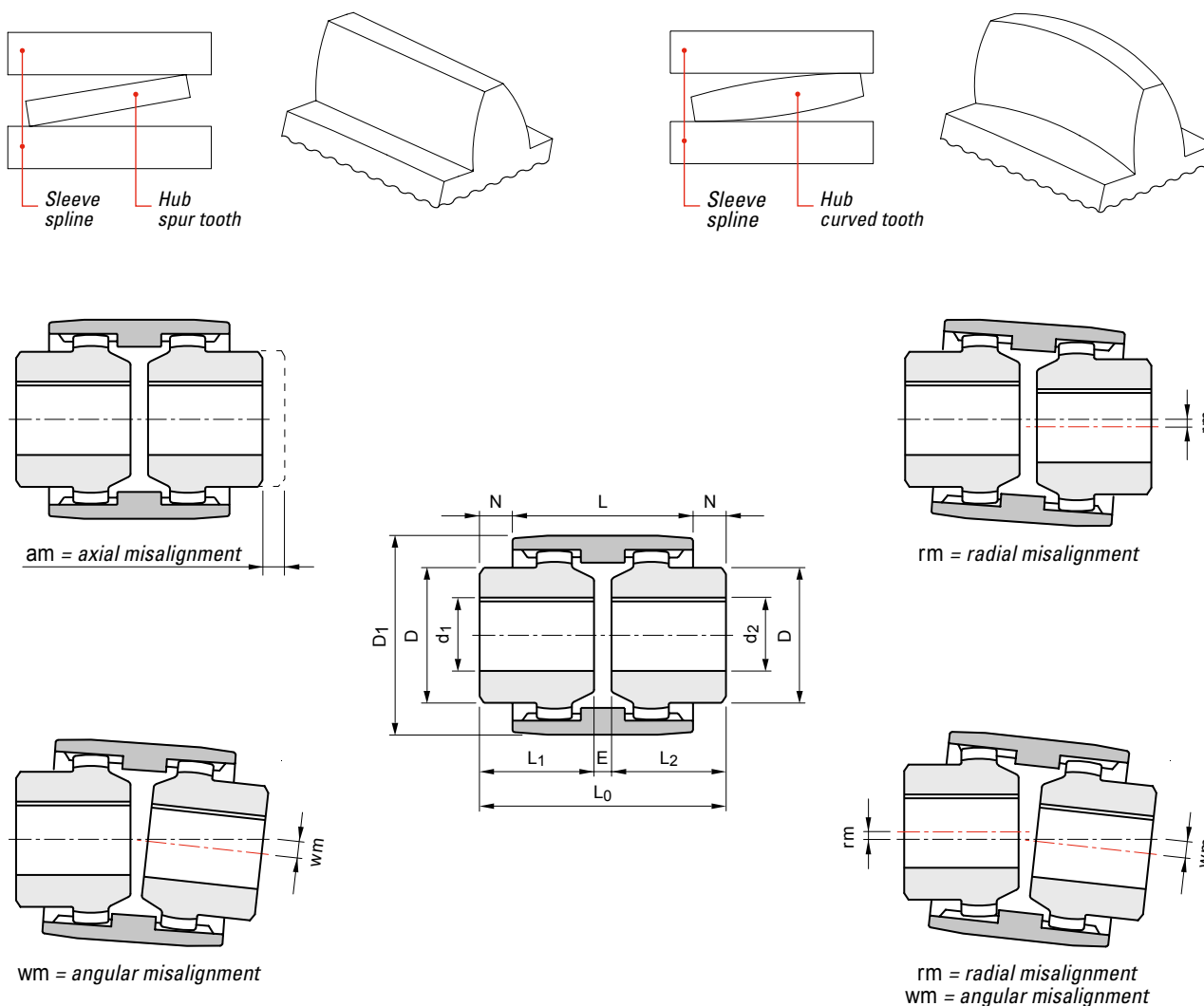





### Nylon-Sleeve Gear Coupling

REFERENCE*	d <sub>1</sub>	d <sub>2</sub>	L	L <sub>0</sub>	N - M	E	L <sub>1</sub> - L <sub>2</sub>	D	D <sub>1</sub>	TORQUE N.m		MAX SPEED rpm	WEIGHT Kg	
	MPB	max								Rated	max		Hub	Sleeve
TL-GC14-37		14	37	50	6,50	4	23	24	40	10	30	14000	0,110	0,030
TL-GC19-37		19	37	54	8,50	4	25	30	48	16	48	11800	0,180	0,030
TL-GC24-41		24	41	56	7,50	4	26	36	52	20	60	10600	0,210	0,040
TL-GC28-46		28	46	84	19,00	4	40	44	66	45	135	8500	0,540	0,080
TL-GC32-48		32	48	84	18,00	4	40	50	76	80	180	7500	0,740	0,090
TL-GC38-48		38	48	84	18,00	4	40	58	83	80	240	6700	0,910	0,130
TL-GC42-50		42	50	88	19,00	4	42	65	92	100	300	6000	1,270	0,140
TL-GC48-50		48	50	104	27,00	4	50	67	95	140	420	5600	1,200	0,230
TL-GC55-55		55	58	108	25,00	4	52	82	114	240	800	5000	2,140	0,360
TL-GC65-65		65	68	114	23,00	4	55	95	132	380	1140	4000	3,030	0,550
TL-GC80-93	25	80	93	186	46,50	6	90	124	175	700	2100	3150	9,800	1,130
TL-GC100-102	35	100	102	228	63,00	8	110	152	210	1200	3600	3000	17,690	1,780
TL-GC125-134	45	125	134	290	78,00	10	140	192	270	2500	7500	2120	36,850	3,880

\* All measures in mm.  
 Bore tapered versions of 1:5 and 1:8 are available.  
 Inch bores available.

**Hubs available:** With Feather Keyway & Setscrew - **With Spline Bore:** Metric DIN5480 & Imperial ANSI B92.1 - With Single Clamping Hub & Feather Keyway - With Clamping Hub & Spline Bore.

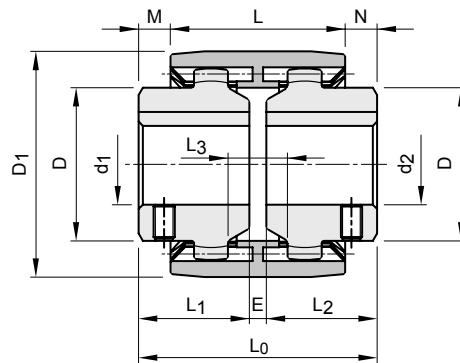

Nylon-Sleeve-Gear-Coupling  
Hub. MPB



Nylon Sleeve

## All metal Gear Coupling

All metal gear coupling is a torsional rigid gear coupling whereas two hubs crowned by gear teeth are connected to the shafts. The crown gear teeth mesh with the internal gear teeth of two flanged sleeves, which in turn are bolted together.

The driving shaft transmits the torque to the driven shaft through the

coupling teeth. This type of coupling absorbs the axial misalignment given that the gear teeth sleeve is far wider than the external hub gear teeth, absorbs angular misalignment as the teeth of the coupling are crowned what permits an angular shift which at the same time benefits to distribute the lubricant film in the teeth flange and improving the wear.

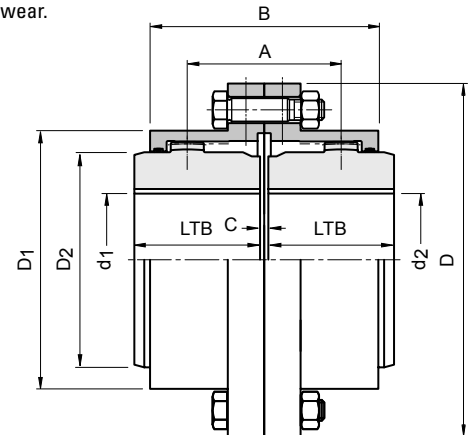

### All Metal Gear Couplings Sizes

REFERENCE*	D	D <sub>1</sub>	D <sub>2</sub>	LTB	C	A	B	d <sub>1</sub> /d <sub>2</sub>	TORQUE	SPEED
TL-GC-A-1	103	71	50	38 to 82	8	36	76	16 to 35	0,40	4000
TL-GC-A-2	115	83	60	39 to 82	8	42	88	20 to 45	0,71	4000
TL-GC-A-3	127	95	75	40 to 82	8	44	90	22 to 55	1,12	4000
TL-GC-A-4	149	116	90	41 to 82	8	49	98	38 to 65	1,80	4000
TL-GC-A-5	157	134	105	42 to 82	10	55	108	40 to 75	3,15	4000
TL-GC-A-6	187	153	125	43 to 82	10	56	110	45 to 90	5,00	4000
TL-GC-A-7	204	170	140	44 to 82	10	60	118	50 to 100	7,10	3735
TL-GC-A-8	230	186	155	45 to 82	12	67	142	55 to 110	10,00	3300
TL-GC-A-9	256	212	180	46 to 82	12	69	146	60 to 130	16,00	3000
TL-GC-A-10	287	239	200	47 to 82	14	78	164	65 to 150	22,40	2650
TL-GC-A-11	325	276	235	48 to 82	14	81	170	70 to 175	35,50	2350
TL-GC-A-12	362	313	270	49 to 82	16	89	190	75 to 200	50,00	2100
TL-GC-A-13	412	350	300	50 to 82	18	98	208	150 to 220	71,00	1850
TL-GC-A-14	462	420	335	51 to 82	22	172	296	170 to 250	112,00	1650
TL-GC-A-15	512	470	380	52 to 82	22	182	316	190 to 280	180,00	1500
TL-GC-A-16	580	522	430	53 to 82	28	209	354	220 to 320	250,00	1300
TL-GC-A-17	644	582	490	54 to 82	28	198	364	250 to 360	355,00	1200
TL-GC-A-18	726	658	540	55 to 82	32	222	430	280 to 400	500,00	1050
TL-GC-A-19	818	748	630	56 to 82	32	232	440	300 to 460	710,00	950
TL-GC-A-20	928	838	720	57 to 82	32	247	470	360 to 530	1000	800
TL-GC-A-21	1022	928	810	58 to 82	40	255	490	400 to 600	1400	750
TL-GC-A-22	1134	1036	915	59 to 82	40	262	510	450 to 670	1800	650
TL-GC-A-23	1282	1178	1030	60 to 82	50	299	580	530 to 750	2500	600
TL-GC-A-24	1428	1322	1175	61 to 82	50	317	610	560 to 850	3550	550
TL-GC-A-25	1644	1538	1390	62 to 82	50	325	620	670 to 1000	4500	460

\* All measures in mm unless otherwise indicated.  
Delivery choice: MPB, Keyway.

### GUIDE TO ORDER

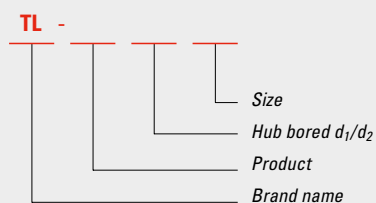

**Size:**  
GC 40 to 270  
GC-A 103 to 1644

**Hub Bored d<sub>1</sub>/d<sub>2</sub>:**  
**GC: 1** With feather keyway and Set Screw.  
**2** With Spline Bore:  
2.1 Metric  
2.2 Imperial  
**3** With Clamping hub and feather keyway.  
**4** With Clamping hub and Spline Bore.

**Product**  
GC Gear Coupling  
GC-A Gear Coupling

**Brand name:**  
**TL**

**GC-A:** Feather Keyway